

Joint Admission and Matriculation Board

JAMB

MATHEMATICS

Past Questions

HOW TO GET REAL 2022 JAMB QUE & ANS

for 2022 JAMB tap => [http:// bestutme. websites. co. in](http://bestutme.websites.co.in)

for 2022 JAMB tap => [http:// bestutme. websites. co. in](http://bestutme.websites.co.in)

for 2022 JAMB tap => [http:// bestutme. websites. co. in](http://bestutme.websites.co.in)

~~NOT FOR SALE~~

All JAMB past questions are **FREE OF CHARGE** for **Toppers**. If someone **sold** this past question to you, please [report him/her to us](#).

PAPER TYPE: B

1. Which Mathematics Question Paper Type is given to you?

- A. Type A
- B. Type B
- C. Type C
- D. Type D

2. Find r , if $6r7_8 = 511_9$

- A. 5
- B. 2
- C. s
- D. 6

3. Simplify $\frac{1}{25} - \frac{1}{4} - \frac{1}{5}$

- A. $\frac{1}{25}$
- B. $\frac{1}{4}$
- C. $\frac{1}{5}$
- D. $\frac{1}{36}$

4. A student measures a piece of rope and found that it was 1.26 m long. If the actual length of the rope was 1.25 m, what was the

percentage error in the measurement?

- A. 0.40%
- B. 0.01%
- C. 0.25%
- D. 0.80%

5. At what rate will be interest on ₦400 increase to ₦ 24 in 3 years reckoning in simple interest?

- A. 4%
- B. 2%
- C. 3%
- D. 5%

6. If $p:q = 2:3$ and $q:r = 4:5$ find $p:r$.

- A. 9:10:15
- B. 12:15:16
- C. 12:15:10
- D. 10:15:24

7. Evaluate $\frac{1}{2} \times \frac{3}{4}$

- A. -
- B. 6
- C. 3
- D. -

8. Given that $\log 2 = 0.3010$, $\log 7 = 0.8451$. Evaluate $\log 112$.

- A. 2.5441
- B. 2.0491
- C. 2.1461
- D. 3.1461

9. Rationalise $2\sqrt{3} + \sqrt{5}$
 $\sqrt{5} - \sqrt{3}$

- A. $\frac{-}{-}$
- B. $\frac{-}{-}$
- C. $3\sqrt{15} - 11$
- D. $3\sqrt{15} - 11$

10. Express the product of 0.21 and 0.34 in standard form

- A. 7.14×10^{-3}
- B. 7.14×10^{-1}
- C. 7.14×10^{-2}
- D. 7.14×10^{-4}

11. Which of the Venn diagrams below represents $P' \cap Q' \cap R'$?

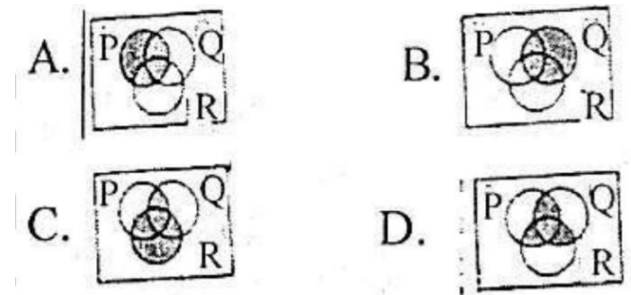

12. In a survey of 50 newspaper readers, 40 read Champion and 30 read Guardian, how many read both papers?

- A. 15
- B. 5
- C. 10
- D. 20

13. Make Q the subject of formula if $P(X + Q) + 1$

- A. _____
- B. _____
- C. _____
- D. _____

14. If $9x^2 + 6xy + 4y^2$ is a factor of $27x^3 - 8y^3$, find the other factor.

- A. $3x - 2y$
- B. $2y - 3x$
- C. $2y + 3x$
- D. $3x + 2y$

15. Factorize completely _____

- A. _____
- B. _____
- C. _____
- D. _____

16. Solve for x and y if $x - y = 2$ and $x^2 - y^2 = 8$

- A. (1, 3)
- B. (3, 1)
- C. (-1, 3)
- D. (-3, 1)

17. If y varies directly as the square root of x and $y = 3$ when $x = 16$, calculate y when $x = 64$

- A. 5
- B. 12
- C. 6
- D. 3

18. If x is inversely proportional to y and $x = \frac{1}{2}$ when $y = 2$, find x if $y = 4$

- A. $\frac{1}{4}$
- B. 5
- C. 4
- D. $\frac{1}{2}$

19. For what range of values of x is $x^2 - 5x + 6 > 0$

- A. $x > 2$
- B. $x > 3$
- C. $x < 2$
- D. $x > 3$

20. Solve the inequalities $-6 \leq 4 - 2 < 5 -$

- A. $-1 \leq x < 6$
- B. $-1 < x \leq 5$

C. $-1 < x < 5$

D. $-1 \leq x \leq 6$

21. Find the sum to infinity of the following series. $0.5 + 0.05 + 0.005 + 0.0005 + \dots$

A. $-\frac{1}{4}$

B. $-\frac{1}{5}$

C. $-\frac{1}{6}$

D. $-\frac{1}{7}$

22. The 3rd term of an arithmetic progression is -9 and the 7th term is -29. Find the 10th term of the progression

A. 44

B. -165

C. -44

D. 165

23. If $x * y = x + y^2$, find then value of $(2*3)*5$

A. 36

B. 11

C. 25

D. 55

24. If p and q are two non-zero numbers and $18(p + q) = (18 + p)q$, which of the following must be true?

A. $q = 18$

B. $p = 18$

C. $p < 1$

D. $q < 1$

25. If $\frac{1}{x} = 15$, find the value of x

A. 3

B. 5

C. 4

D. 2

26. Evaluate

A. -42

B. 102

C. 18

D. -102

27. If $P =$, what is P^{-1}

- A. - -
- B. - -
- C. - -
- D. - -

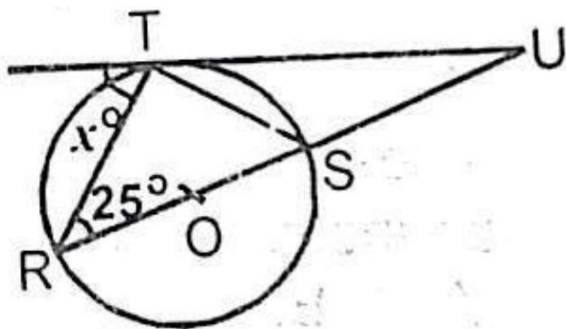

28. From the diagram above, find x

- A. 65°
- B. 50°
- C. 55°
- D. 75°

29. The interior angles of a quadrilateral are $(x + 15)^\circ$, $(2x -$

$45)^\circ$ and $(x + 10)^\circ$. Find the value of the least interior angle.

- A. 102°
- B. 52°
- C. 82°
- D. 112°

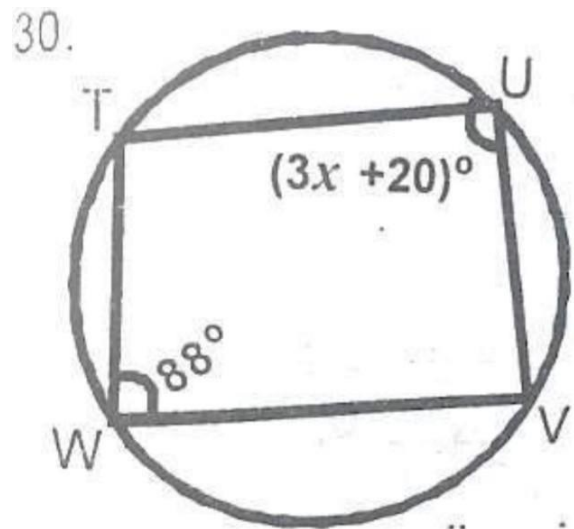

30. From the cyclic quadrilateral TUVW above, find the value of x

- A. 23°
- B. 26°
- C. 24°
- D. 20°

31. If the two smaller sides of a right-angled triangle are 4 cm and 5 cm, find its area.

- A. 10 cm^2

- B. 6 cm^2
- C. 8 cm^2
- D. 24 cm^2

32. An arc subtends an angle of 50° at the centre of circle of radius 6cm. Calculate the area of the sector formed

- A. $\frac{1}{2} \text{ cm}^2$
- B. $\frac{1}{4} \text{ cm}^2$
- C. $\frac{1}{8} \text{ cm}^2$
- D. $\frac{1}{16} \text{ cm}^2$

33. A cylindrical pipe 50cm long with radius 7m has one end open. What is the total surface area of the pipe?

- A. 700 cm^2
- B. 98 cm^2
- C. 350 cm^2
- D. 749 cm^2

34. What is the locus of point that is equidistant from points P(1,3) and Q(3,5)?

- A. $y = -x + 6$
- B. $y = -x + 6$
- C. $y = -x - 6$
- D. $y = x - 6$

35. Find the distance between the points $(-1, -1)$ and $(1, -1)$

- A. $\sqrt{2}$
- B. 0
- C. 1
- D. $\sqrt{3}$

36. Find the gradient of the line passing through the points P(1, 1) and Q(2, 5).

- A. 4
- B. 2
- C. 3
- D. 5

37. Find the equation of a line parallel to $y = -4x + 2$ passing through (2,3)

- A. $y - 4x + 11 = 0$
- B. $y - 4x - 11 = 0$
- C. $y + 4x + 11 = 0$

D. $y + 4x - 11 = 0$

38. If $\cot \theta = \frac{1}{2}$, where θ is acute, find $\sin \theta$

- A. $\frac{1}{2}$
- B. $\frac{2}{3}$
- C. $\frac{3}{5}$
- D. $\frac{4}{5}$

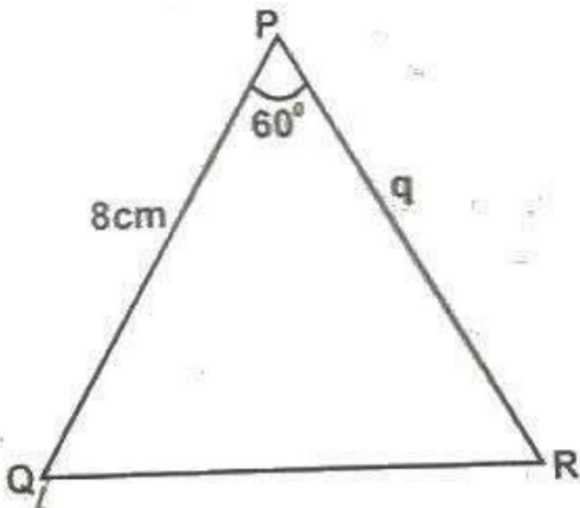

39. If the area of $\triangle PQR$ above is $12\sqrt{3} \text{ cm}^2$, find the value of q ?

- A. 6 cm
- B. 8 cm
- C. 7 cm
- D. 5 cm

40. If $y = (2x + 1)^3$, find $\frac{dy}{dx}$

A. $3(2x+1)^2$

B. $3(2x + 1)$

C. $6(2x + 1)$

D. $6(2x+1)^2$

41. If $y = x \sin x$, find $\frac{dy}{dx}$

- A. $x + \cos x$
- B. $x + \sin x$
- C. $x - \cos x$
- D. $x - \sin x$

42. At what value of X does the function $y = -3 - 2x + x^2$ attain a minimum value?

- A. 1
- B. -4
- C. -1
- D. 4

43. Evaluate $\int_0^1 dx$

- A. 2
- B. 6
- C. 4
- D. 12

44. Find $\int (\sin x + 2) dx$

- A. $\cos x + x^2 + k$
- B. $\cos x + 2x + k$
- C. $-\cos x + 2x + k$
- D. $-\cos x + x^2 + k$

45.

Marks	2	3	4	5	6	7	8
Students	3	1	5	2	4	2	3

From the table above, if the pass mark is 5, how many students failed the test?

- A. 7
- B. 2
- C. 6
- D. 9

Use the table below to answer question 46 and 47

Marks	1	2	3	4
Frequency	2	2	8	4

46. The table above shows the marks obtained in a given test. How many students failed the test?

- A. 15

- B. 20
- C. 16
- D. 13

47. Find the mean mark

- A. 3.2
- B. 3.0
- C. 3.1
- D. 3.3

48. Find the standard deviation of 2, 3, 5 and 6

- A. $\sqrt{2}$
- B. $\sqrt{3}$
- C. $\sqrt{5}$
- D. $\sqrt{6}$

49. In how many ways can a committee of 2 women and 3 men be chosen from 6 men and 5 women?

- A. 50
- B. 200
- C. 100
- D. 30

50. If three unbiased coins are tossed, find the probability that they are all heads.

A. –

B. –

C. –

D. –

ANSWERS

1. B 2. C 3. D 4. D 5. B 6. C 7. A
8. B 9. A 10. C 11. A 12. D 13. B
14. A 15. A 16. B 17. C 18. D
19. B 20. B 21. A 22. C 23. A
24. A 25. A

26. D 27. B 28. A 29. B 30. C
31. A 32. B 33. D 34. A 35. A
36. A 37. D 38. B 39. A 40. D
41. B 42. C 43. B 44. C 45. D
46. B 47. D 48. A 49. B 50. A

Facebook Study Group

If you need an **explanation** to any of the answers or you want to **download** more past questions for FREE.

Click to **ENTER** our Facebook
study group



TYPE: D

1. Which Mathematics Question Paper Type is given to you?

- A. Type A
- B. Type B
- C. Type C
- D. Type D

2. If $2_q3_5 = 77_8$, find q

- A. 2
- B. 1
- C. 4
- D. 0

3. Simplify $\frac{---}{---}$

- A. 5
- B. 30
- C. 4
- D. 50

4. A man invested ₦5,000 for 9 months at 4%. What is the simple interest?

- A. ₦150
- B. ₦220
- C. ₦130
- D. ₦250

5. If the numbers M, N, Q are in the ratio 5:4:3, find the value of

- A. 2
- B. 3
- C. 1
- D. 4

6. Simplify $\frac{---}{---}$

- A. 23
- B. 12
- C. 89
- D. 13

7. If $\log_3 18 + \log_3 3 - \log_3 x = 3$, find x.

- A. 1
- B. 2
- C. 0

D. 3

8. Rationalize $\frac{1}{\sqrt{2}}$

A. $\frac{\sqrt{2}}{2}$

B. $\frac{1}{2}$

C. $\frac{\sqrt{2}}{4}$

D. $\frac{1}{4}$

9. Simplify $\frac{1}{\sqrt{2}} - \frac{1}{\sqrt{2}}$

A. 0

B. -1

C. 1

D. -2

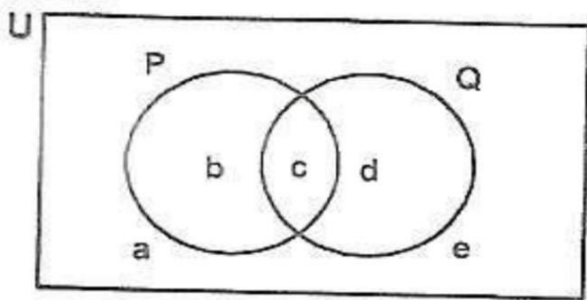

10. From the Venn diagram above, the complement of the set $P \cap Q$ is given by

A. {a, b, d, e}

B. {b, d}

C. {a, e}

D. {c}

11. Raial has 7 different posters to be hanged in her bedroom, living room and kitchen. Assuming she has plans to place at least a poster in each of the 3 rooms, how many choices does she have?

A. 49

B. 170

C. 21

D. 210

12. Make R the subject of the formula if $T = \frac{R}{R+1}$

A. $\frac{1}{T-1}$

B. $\frac{1}{T+1}$

C. $\frac{1}{1-T}$

D. $\frac{1}{1+T}$

13. Find the remainder when $3x^3 - 2x^2 + 3x - 3$ is divided by $x^2 + 1$

- A. $2x - 1$
- B. $x + 3$
- C. $2x + 1$
- D. $x - 3$

14. Factorize completely $9y^2 - 16x^2$

- A. $(3y - 2x)(3y + 4x)$
- B. $(3y + 4x)(3y + 4x)$
- C. $(3y + 2x)(3y - 4x)$
- D. $(3y - 4x)(3y + 4x)$

15. Solve for x and y respectively in the simultaneous equations $-2x - 5y = 3$, $x + 3y = 0$

- A. -3, -9
- B. 9, -3
- C. -9, 3
- D. 3, -9

16. If x varies directly as square root of y and $x = 81$ when $y = 9$, Find x when $y = 1$

- A. 20
- B. 27
- C. 2
- D. 36

17. T varies inversely as the cube of R. When $R = 3$, $T = 8$, find T when $R = 2$

- A. 10
- B. 12
- C. 15
- D. 18

18. Which of the following diagrams represents the solution of the inequalities $y \leq x - 2$ and $y \geq x^2 - 4$?

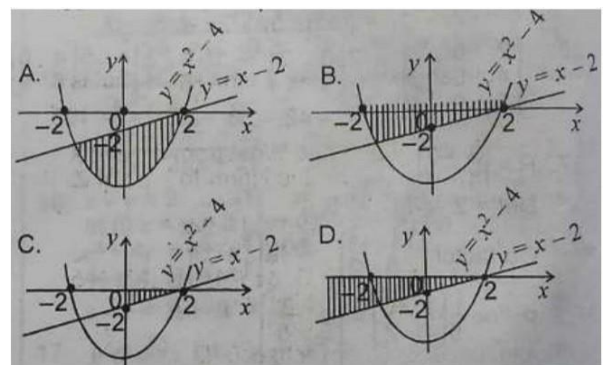

19. Solve the inequality $-6(x + 3) \leq 4(x - 2)$

- A. $x \leq 2$
- B. $x \geq -1$
- C. $x \geq -2$
- D. $x \leq -1$

20. Solve the inequality $2 + 2 > 15$.

- A. $x < -3$ or $x > 5$
- B. $-5 < x < 3$
- C. $x < 3$ or $x > 5$
- D. $x > 3$ or $x < -5$

21. Find the sum of the first 18 terms of the series 3, 6, 9..., 36.

- A. 505
- B. 513
- C. 433
- D. 635

22. The second term of a geometric series is 4 while the fourth term is 16. Find the sum of the first five terms

- A. 60
- B. 62
- C. 54

D. 64

23. A binary operation \oplus on real numbers is defined by $x \oplus y = xy + x + y$ for two real numbers x and y . Find the value of $3 \oplus -$

- A. -
- B. -
- C. -1
- D. 2

24. If , find the value of x.

- A. -6
- B. 6
- C. -12
- D. 12

25. Evaluate

- A. 25
- B. 45
- C. 15
- D. 55

26. The inverse of matrix $N =$
is

A. –

B. –

C. –

D. –

27. What is the size of each interior angle of a 12-sided regular polygon?

A. 120°

B. 150°

C. 30°

D. 180°

28. A circle of perimeter 28cm is opened to form a square. What is the maximum possible area of the square?

A. 56 cm^2

B. 49 cm^2

C. 98 cm^2

D. 28 cm^2

29. A chord of circle of radius 7 cm is 5 cm from the centre of the maximum possible area of the square?

A. $4\sqrt{6} \text{ cm}^2$

B. $3\sqrt{6} \text{ cm}^2$

C. $6\sqrt{6} \text{ cm}^2$

D. $2\sqrt{6} \text{ cm}^2$

30. A solid metal cube of side 3 cm is placed in a rectangular tank of dimension 3, 4 and 5 cm. What volume of water can the tank now hold?

A. 48 cm^3

B. 33 cm^3

C. 60 cm^3

D. 27 cm^3

31. The perpendicular bisector of a line \mathbf{XY} is the locus of a point

A. whose distance from \mathbf{X} is always twice its distance from \mathbf{Y}

B. whose distance from \mathbf{Y} is always twice its distance from \mathbf{X}

C. which moves on the line \mathbf{XY}

D. which is equidistant from the points X and y

32. The midpoint of P(x, y) and Q(8, 6). Find x and y. midpoint = (5, 8)

- A. (2, 10)
- B. (2, 8)
- C. (2, 12)
- D. (2, 6)

33. Find the equation of a line perpendicular to line $2 = 5 + 4$ which passes through (4, 2).

- A. $5 - 2 - 18 = 0$
- B. $5 + 2 - 18 = 0$
- C. $5 - 2 + 18 = 0$
- D. $5 + 2 - 2 = 0$

34. In a right-angled triangle, if $\tan \theta = 3/4$. What is $\sin \theta$?

- A. $3/5$
- B. $4/5$
- C. $3/4$
- D. $4/3$

35. A man walks 100 m due West from a point X to Y, he then walks 100 m due North to a point Z. Find the bearing of X from Z.

- A. 195°
- B. 135°
- C. 225°
- D. 045°

36. The derivatives of $(2x + 1)(3x + 1)$ is

- A. $12x + 1$
- B. $6x + 5$
- C. $6x + 1$
- D. $12x + 5$

37. Find the derivative of $x^2 + 2x + 1$

- A. 2
- B. $2x + 2$
- C. $2x + 1$
- D. 2

38. Find the value of x at the minimum point of the curve $y = x^3 + 2x^2 - 3x + 1$

- A. -
- B. --
- C. 1
- D. 1

39. Evaluate

- A. 3
- B. 5
- C. 2
- D. 6

40. Find $\int \cos 4$

- A. $\sin 4 +$
- B. $-\sin 4 +$
- C. $-\sin 4 +$
- D. $\sin 4 +$

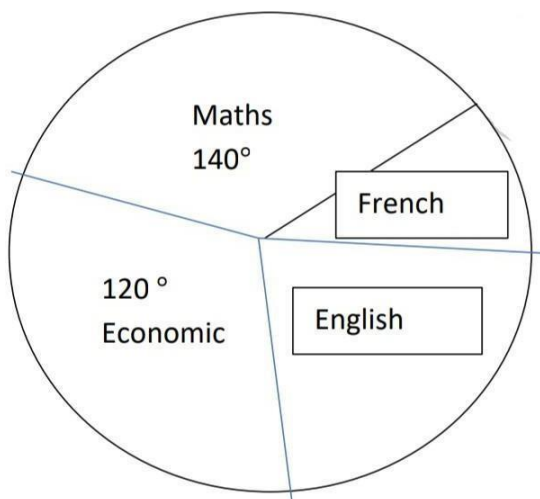

41. The pie chart shows the distribution of courses offered by students. What percentage of the students offer English?

- A. 30%
- B. 25%
- C. 35%
- D. 20%

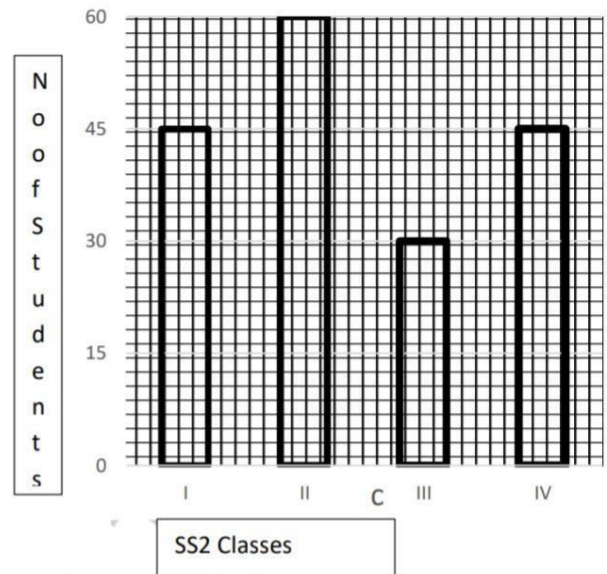

42. The bar chart above shows the distribution of SS2 students in a school. Find the total number of students

- A. 180
- B. 135
- C. 210
- D. 105

43. The sum of four consecutive integers is 34. Find the least of these numbers

- A. 7
- B. 6
- C. 8
- D. 5

Number	0	1	2	3	5
Frequency	1	4	8	2	5

44. From the table above, find the median and range of the data respectively.

- A. (8,5)
- B. (3, 5)
- C. (5, 8)
- D. (5, 3)

Class Interval	0-2	3-5	6-8	9-11
Frequency	3	2	5	3

45. Find the mode of the above distribution

- A. 9
- B. 8
- C. 10

D. 7

Class Interval	3-5	6-8	9-11
Frequency	2	2	2

46. Find the standard deviation of the above distribution.

- A. $\sqrt{5}$
- B. $\sqrt{3}$
- C. $\sqrt{7}$
- D. $\sqrt{2}$

47. In how many ways can the letters of the word ELATION be arranged?

- A. 6!
- B. 7!
- C. 5!
- D. 8!

48. In how many ways can five people sit round a circular table?

- A. 24
- B. 60
- C. 12
- D. 120

49. Find the probability that a number picked at random from the set (43, 44, 45, ..., 60) is a prime number.

- A. –
- B. –
- C. –
- D. –

50. In a class of 60 students, 30 offer Physics and 40 offer Chemistry. If a student is picked at random from the class, what is the probability that the student offers both Physics and Chemistry?

- A. –
- B. –
- C. –
- D. –

ANSWERS

1. **D** 2. **A** 3. **D** 4. **A** 5. **C** 6. **B** 7. **B**
8. **B** 9. **B** 10. **A** 11. **D** 12. **D** 13. **A**

14. **D** 15. **C** 16. **D** 17. **B** 18. **B** 19. **B**
20. **B** 21. **B** 22. **B** 23. **B** 24. **A**
25. **A**

26. **B** 27. **B** 28. **B** 29. **A** 30. **B** 31. **D**
32. **A** 33. **B** 34. **C** 35. **B** 36. **D**
37. **A** 38. **B** 39. **C** 40. **A** 41. **B** 42. **A**
43. **A** 44. **B** 45. **D** 46. **B** 47. **B**
48. **B** 49. **C** 50. **A**

TYPE: GREEN

1. Which Question Paper Type of Mathematics as indicated above is given to you?

- A. Type Green
- B. Type Purple
- C. Type Red
- D. Type Yellow

2. Convert 72_6 to a number in base three

- A. 2211
- B. 2121
- C. 1212
- D. 1122

3. Simplify $\frac{114}{56}$

- A. 114
- B. 116
- C. 56
- D. 45

4. Evaluate 2.333 to 3 significant figures

- A. 2.30
- B. 2.31
- C. 2.32
- D. 2.33

5. A man earns ₦3,500 per month out of which he spends 15% on his children's education. If he spends additional ₦1,950 on food, how much does he have left?

- A. ₦525
- B. ₦1,025
- C. ₦1,950
- D. ₦2,975

6. If $27^{x+2} \div 9^{x+1} = 3^{2x}$, find x

- A. 3
- B. 4
- C. 5
- D. 6

7. If $\log_3 2 = -8$, what is x?

- A. 13
- B. 19
- C. 127
- D. 181

8. Simplify $(\sqrt{6} + 2)^2 - (\sqrt{6} - 2)^2$

- A. $2\sqrt{6}$
- B. $4\sqrt{6}$
- C. $8\sqrt{6}$
- D. $16\sqrt{6}$

9. If P is a set of all prime factors of 30 and Q is a set of all factors of 18 less than 10, find $P \cap Q$

- A. {3}
- B. {2,3}
- C. {2,3,5}
- D. {1,2}

10. In a class of 46 students, 22 play football and 26 play volleyball. If 3 students play both games, how many play neither?

- A. 1
- B. 2
- C. 3

D. 4

11. Make 'n' the subject of the formula if $w = \frac{2n-1}{n+1}$

- A. $n = \frac{w+1}{2w-1}$
- B. $n = \frac{w-1}{2w+1}$
- C. $n = \frac{w+1}{2w+1}$
- D. $n = \frac{w-1}{2w-1}$

12. Find the remainder when $2x^3 - 11x^2 + 8x - 1$ is divided by $x + 3$

- A. -871
- B. -781
- C. -187
- D. -178

13. Solve for x and y in the equations below

$$x^2 - y^2 = 4$$

$$x + y = 2$$

- A. $x = 0, y = -2$
- B. $x = 0, y = 2$
- C. $x = 2, y = 0$
- D. $x = -2, y = 0$

14. If y varies directly as $\sqrt{}$ and $y = 4$ when $n = 4$, find y when $n = 1$ -

- A. $\sqrt{17}$
- B. -
- C. -
- D. -

15. U is inversely proportional to the cube of V and $U = 81$ when $V = 2$. Find U when $V = 3$

- A. 24
- B. 27
- C. 32
- D. 36

16. The value of y for which - - - is

- A. $y > -$
- B. $y < -$
- C. $y > -$
- D. $y < -$

17. Find the range of values of m which satisfy $(m - 3)(m - 4) < 0$

- A. $2 < m < 5$
- B. $-3 < m < 4$
- C. $3 < m < 4$
- D. $-4 < m < 3$

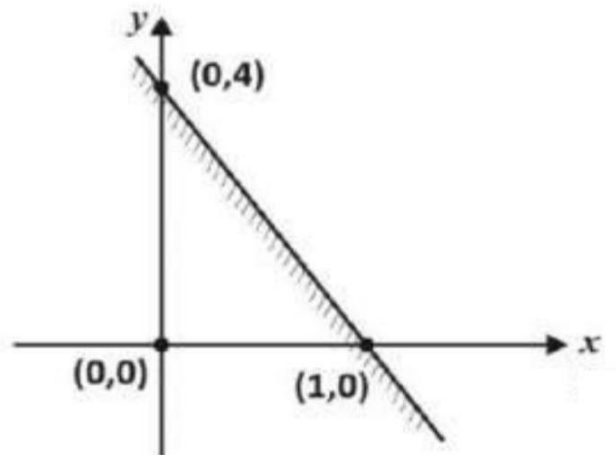

18. The shaded region above is represented by the equation

- A. $y \leq 4x + 2$
- B. $y \geq 4x + 2$
- C. $y \leq -4x + 4$
- D. $y \leq 4x + 4$

19. The n th term of a sequence is $n^2 - 6n - 4$. Find the sum of the 3rd and 4th terms.

- A. 24
- B. 23

C. -24

D. -25

20. The sum to infinity of a geometric progression is $-\frac{1}{2}$ and the first term is $-\frac{1}{4}$. Find the common ratio of the progression.

A. $-\frac{1}{2}$

B. $-\frac{1}{4}$

C. $-\frac{1}{8}$

D. $-\frac{1}{16}$

21. The binary operation $*$ is defined on the set of integers such that $p * q = pq + p - q$. Find $2 * (3 * 4)$

A. 11

B. 13

C. 15

D. 22

22. The binary operation on the set of real numbers is defined by $m * n = mn^2$ for all $m, n \in \mathbb{R}$. If the identity element is 2, find the inverse of -5

A. -45

B. -25

C. 4

D. 5

23. If $\sin^{-1} \left(\frac{1}{\sqrt{2}} \right) = x$, find the value of x

A. 3

B. 4

C. 5

D. 7

24. Given that I_3 is a unit matrix of order 3, find $|I_3|$

A. -1

B. 0

C. 1

D. 2

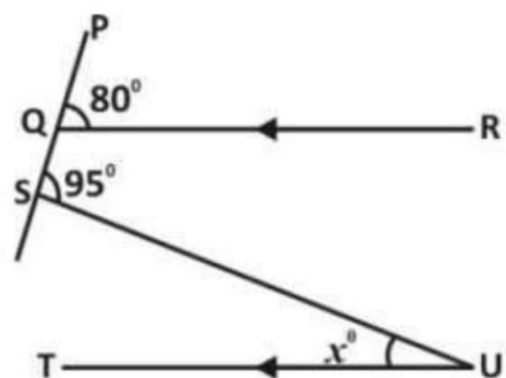

25. In diagram above, $QR \parallel TU$,
 $\angle PQR = 80^\circ$ and $\angle PSU = 95^\circ$.
 Calculate $\angle SUT$.

- A. 15°
- B. 25°
- C. 30°
- D. 80°

26. The angles of a polygon are given by x , $2x$, $3x$, $4x$ and $5x$ respectively. Find the value of x .

- A. 24°
- B. 30°
- C. 33°
- D. 36°

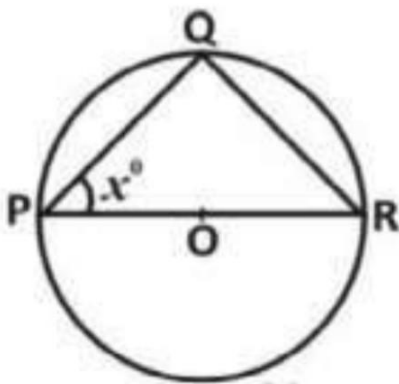

27. In the diagram above, PQR is a circle centre O . If $\angle QPR$ is x° , find $\angle QRP$.

- A. x°

- B. $(90 - x)^\circ$
- C. $(90 + x)^\circ$
- D. $(180 - x)^\circ$

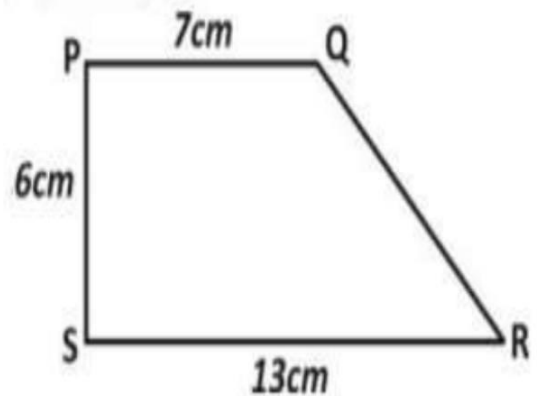

28. Find the area of the trapezium above.

- A. 91 cm^2
- B. 78 cm^2
- C. 60 cm^2
- D. 19 cm^2

29. A circular arc subtends angle 150° at the centre of a circle of radius 12 cm . Calculate the area of the sector of the arc?

- A. $30 \pi \text{ cm}^2$
- B. $60 \pi \text{ cm}^2$
- C. $120 \pi \text{ cm}^2$
- D. $150 \pi \text{ cm}^2$

30. Calculate the volume of a cuboid of length 0.76 cm, breadth 2.6 cm and height 0.82 cm.

- A. 3.92 cm³
- B. 2.13 cm³
- C. 1.97 cm³
- D. 1.62 cm³

31. The locus of a point equidistant from the intersection of lines $3x - 7y + 7 = 0$ and $4x - 6y + 1 = 0$ is a

- A. line parallel to $7x + 13y + 8 = 0$
- B. circle
- C. semicircle
- D. bisector of the line $7x + 13y + 8 = 0$

32. The gradient of the straight line joining the points P(5, -7) and Q(-2, -3) is

- A. 12
- B. 25
- C. -47
- D. -23

33. The distance between the point (4, 3) and the intersection of $x + 2y = 7$ and $x - y = 2$ is

- A. $\sqrt{13}$
- B. $3\sqrt{2}$
- C. $\sqrt{26}$
- D. $10\sqrt{5}$

34. Find the equation of the line through the points (-2, 1) and (2, 4)

- A. $y = 2x - 3$
- B. $y = 2x + 5$
- C. $y = 3x - 2$
- D. $y = 2x + 1$

35. If angle θ is 135° , evaluate $\cos \theta$

- A. -
- B. $-\frac{1}{\sqrt{2}}$
- C. $-\frac{1}{2}$
- D. $-\frac{\sqrt{2}}{2}$

36. A man stands on a tree 150cm high and sees a boat at an

angle of depression of 74° . Find the distance of the boat from the base of the tree.

- A. 52 cm
- B. 43 cm
- C. 40 cm
- D. 15 cm

37. If $y = x^2 - 7$ find —

- A. $2x - \underline{\hspace{1cm}}$
- B. $2x + x^2$
- C. $2x - x^2$
- D. $2x + \underline{\hspace{1cm}}$

38. Find $\sin \theta = \cos$

- A. \sin
- B. $-\sin$
- C. \tan
- D. $-\tan$

39. Evaluate $(2 - 4)^2$

- A. —
- B. —

C. —

D. —

40. Evaluate 2^{-2}

- A. 1
- B. 2
- C. 3
- D. 4



41. The grades of 36 students in a class test are as shown in the pie chart above. How many students have excellent?

- A. 12
- B. 9
- C. 8
- D. 7

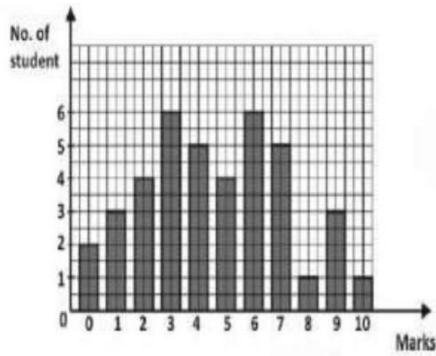

42. The bar chart above shows the distribution of marks in a class test. If the pass mark is 5, what percentage of students failed the test?

- A. 10%
- B. 20%
- C. 50%
- D. 60%

43. The mean of seven numbers is 96. If an eighth number is added, the mean becomes 112. Find the eighth number.

- A. 126
- B. 180
- C. 216
- D. 224

44. Find the median of 2, 3, 7, 3, 4, 5, 8, 9, 9, 4, 5, 3, 4, 2, 4 and 5

- A. 9
- B. 8
- C. 7
- D. 4

45. Find the range of 4, 9, 6, 3, 2, 8, 10 and 11

- A. 11
- B. 9
- C. 8
- D. 4

46. Find the standard deviation of 2, 3, 8, 10 and 12

- A. 3.9
- B. 4.9
- C. 5.9
- D. 6.9

47. Evaluate ${}^{n+1}C_{n-2}$ If $n = 15$

- A. 3630
- B. 3360
- C. 1120
- D. 560

48. In how many ways can the letters of the word TOTALITY be arranged?

- A. 6720
- B. 6270
- C. 6207
- D. 6027

49. The probability that a student passes a physics test is $\frac{1}{2}$. If he takes three physics tests, what is the probability that he passes two of the tests?

- A. $\frac{1}{8}$
- B. $\frac{3}{8}$
- C. $\frac{3}{4}$
- D. $\frac{7}{8}$

50. The probabilities that a man and his wife live for 80 years are $\frac{1}{2}$ and $\frac{1}{3}$ respectively. Find the probability that at least one of them will live up to 80 years

- A. $\frac{1}{6}$

B. $\frac{1}{2}$

C. $\frac{5}{6}$

D. $\frac{7}{8}$

ANSWERS

- 1. A 2. D 3. D 4. D 5. B 6. B 7. D**
8. C 9. B 10. A 11. A 12. D 13. C
14. C 15. A 16. C 17. B 18. C
19. D 20. B 21. B 22. A 23. C
24. C 25. A
- 26. D 27. B 28. C 29. B 30. D**
31. B 32. C 33. B 34. B 35. C
36. B 37. D 38. B 39. D 40. A
41. D 42. C 43. D 44. D 45. B
46. A 47. D 48. A 49. D 50. D

TYPE: U

1. Which Mathematics Question Paper Type is given to you?

- A. Type D
- B. Type I
- C. Type B
- D. Type U

2. Convert 27_{10} to another number in base three

- A. 1100_3
- B. 1000_3
- C. 1001_3
- D. 1010_3

3. 3 girls share a number of apples in the ration 5:3:2. If the highest share is 40 apples, find the smallest share

- A. 16
- B. 38
- C. 36
- D. 24

4. Evaluate , correct to 1 decimal place

- A. 6.3
- B. 0.5
- C. 0.6
- D. 6.2

5. Calculate the time taken for ₦3000 to earn ₦600 if invested at 8% simple interest

- A. 3 years
- B. $1\bar{}$ years
- C. 2 years
- D. 3 years

6. Simplify $3 - 5 \ 91 - \times 27 + 1$

- A. 32
- B. 33
- C. 35
- D. 3

7. If $\log_{10} 4 = 0.6021$, evaluate \log_{10} -

- A. 1.8063
- B. 0.2007
- C. 0.3011
- D. 0.9021

8. Simplify $\frac{2^3 \times 3^2 \times 5^4}{2^5 \times 3^3 \times 5^2}$

- A. $\frac{1}{5}$
- B. 9
- C. 5
- D. $\frac{1}{9}$

9. P, Q and R are subsets of the universal set U. The Venn diagram showing the relationship $(P \cap Q) \cup R$ is

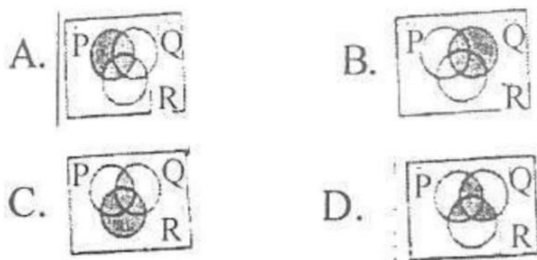

10. if $P = \{x : x^2 - 1 < x \leq 20\}$ and $Q = \{x : x^2 - 2 < x \leq 25\}$, find $P \cap Q$

- A. $\{3, 5, 7, 11, 13, 17, 19\}$
- B. $\{2, 3, 5, 7, 11, 13, 17, 19\}$

- C. $\{3, 5, 7, 11, 17, 19\}$
- D. $\{3, 5, 11, 13, 17, 19\}$

11. If $S = \frac{1}{x^2 - 2}$ find t in terms of S

- A. $S - 2$
- B. $S^2 + 2$
- C. $S^2 - 2$
- D. $S + 2$

12. If $k - 4$ is a factor of $2k^2 - 13k + 14$, then k is

- A. 20
- B. 2
- C. 4
- D. 12

13. The remainder when $63^2 - 2 - 47 + 30$ is divided by -3 is

- A. 63
- B. 18
- C. 21
- D. 42

14. P varies jointly as m and u, and varies inversely as q. Given

that $p = 4$, $m = 3$ and $u = 2$ and $q = 1$, find the value of p when $m = 6$, $u = 4$ and $q = -$

- A. 10
- B. —
- C. —
- D. 15

15. If r varies inversely as the square root of s and t , how does s vary with r and t ?

- A. s varies directly as r^2 and t^2
- B. s varies directly as r and t
- C. s varies inversely as r and t^2
- D. s varies inversely as r^2 and t

16. Evaluate $3(x + 2) > 6(x + 3)$

- A. $x < -4$
- B. $x > 4$
- C. $x < 4$
- D. $x > -4$

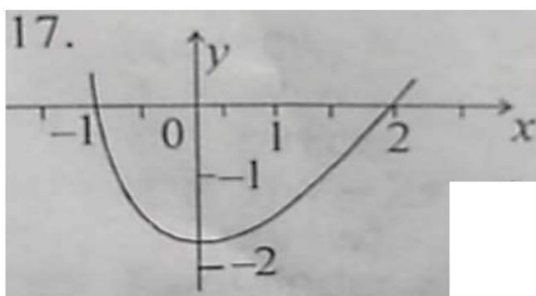

17. The graph above is correctly represented by

- A. $= 2 - - 1$
- B. $= 2 + - 2$
- C. $= 2 - - 2$
- D. $= 2 - 3 + 2$

18. Solve for : $| - 2 | < 3$

- A. $-1 < < 5$
- B. < 1
- C. < 5
- D. $-1 < < 3$

19. If the sum of the first two terms of a G.P. is 3, and the sum of the second and the third terms is -6, find the sum of the first term and the common ratio

- A. -5
- B. 5
- C. -2
- D. -3

20. The n th term of the progression is- — —

- A. —
- B. —
- C. —
- D. —

21. If a binary operation $*$ is defined by $x * y = x + 2y$, find $2 * (3 * 4)$

- A. 14
- B. 26
- C. 24
- D. 16

22. If $P =$ and $Q =$
find $2P + Q$

- A. A.
- B.
- C.
- D.

23. Find the inverse

- A. —
- B. —
- C. —
- D. —

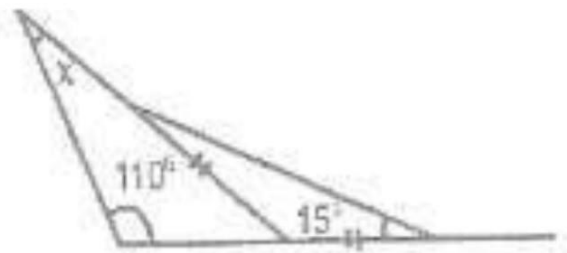

24. In the diagram above, find the value of x .

- A. 5°
- B. 5°
- C. 30°
- D. 40°

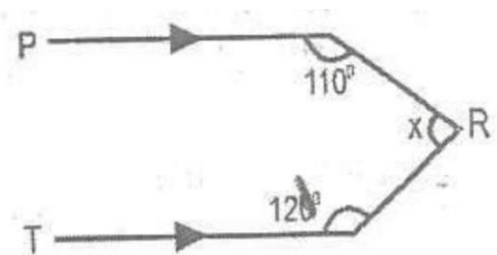

25. The value of x in the figure above is

- A. 70°
- B. 130°
- C. 110°
- D. 100°

26. If the angles of a quadrilateral are $(3y+10)^\circ$, $(2y+30)^\circ$, $(y+20)^\circ$ and $4y^\circ$, find the value of y .

- A. 66°
- B. 12°
- C. 30°
- D. 42°

27. A square tile has side 30cm. How many of these tiles will cover a rectangular floor of length 7.2m and width 4.2m?

- A. 720
- B. 336
- C. 420
- D. 576

28. Find the length of a chord which subtends an angle of 90° at the centre of a circle whose radius is 8cm.

- A. $8\sqrt{3}$ cm
- B. 4 cm
- C. 8 cm
- D. $8\sqrt{2}$ cm

29. A chord of a circle subtends an angle of 120° at the centre of a circle of diameter $4\sqrt{3}$ cm. Calculate the area of the major sector

- A. 32π cm²
- B. 4π cm²
- C. 8π cm²
- D. 16π cm²

30. The locus of the points which is equidistant from the line PQ forms a

- A. perpendicular line to PQ
- B. circle centre P
- C. circle centre Q
- D. pair of parallel lines to PQ

31. If the mid-point of the line PQ is $(2,3)$ and the point P is $(-2,1)$. find the coordinate of the point Q.

- A. (8 ,6)
- B. (5, 6)
- C. (0, 4)
- D. (6, 5)

32. Find the equation of the perpendicular bisector of the line joining P (2, 3) to Q(-5, 1)

- A. $8x + 14y + 13 = 0$
- B. $8x - 14y + 13 = 0$
- C. $8x - 14y - 13 = 0$
- D. $8x + 14y - 13 = 0$

33. In triangle PQR, $q = 8\text{cm}$, $r = 6\text{cm}$ and $\cos p = -$

- A. $\sqrt{108}\text{ cm}$
- B. $\sqrt{9}\text{ cm}$
- C. $\sqrt{92}\text{ cm}$
- D. 10 cm

34. If $\tan \theta = \frac{1}{2}$, find the value of $\sin \theta + \cos \theta$

- A. $\frac{1}{2}$
- B. $\frac{1}{3}$
- C. $\frac{1}{4}$

D. $\frac{1}{5}$

35. If $y = (2x + 2)^3$, find $\frac{dy}{dx}$

- A. $3(2 + 2)$
- B. $6(2 + 2)^2$
- C. $3(2 + 2)^2$
- D. $6(2x+2)$

36. if $y = x \sin \theta$, find $\frac{dy}{dx}$

- A. $\cos \theta + x \sin \theta$
- B. $\sin \theta + x \cos \theta$
- C. $\sin \theta - \cos \theta$
- D. $\cos \theta - x \sin \theta$

37. The radius of a circle is increasing at the rate of 0.02cm s^{-1} . Find the rate at which the area is increasing when the radius of the circle is 7cm .

- A. $0.35\text{ cm}^2\text{S}^{-1}$
- B. $0.88\text{cm}^2\text{S}^{-1}$
- C. $0.75\text{ cm}^2\text{S}^{-1}$
- D. $0.55\text{ cm}^2\text{S}^{-1}$

38. Integrate $\frac{1}{x^2}$

A. $2x^2 - \dots + k$

B. $-\dots - \dots + k$

C. $-\dots - \dots \pm k$

D. $x^2 - \dots + k$

39. Evaluate \dots

A. -2

B. 2

C. 1

D. -1

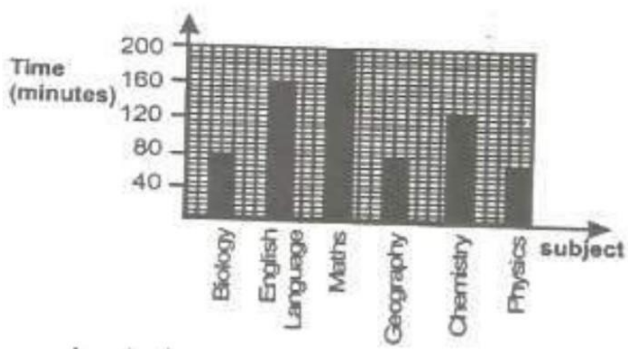

40. The bar chart above shows the allotment of time (in minutes) per week for selected subjects in a certain school. What is the total time allocated to the six subjects per week?

A. 960 mins

B. 200 mins

C. 460 mins

D. 720 mins

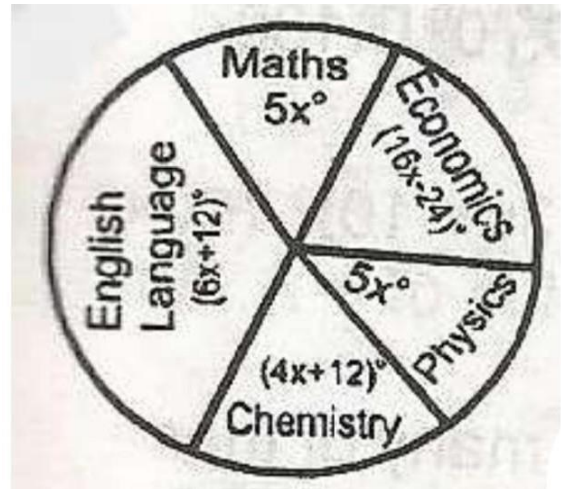

41. The pie chart above shows the statistical distribution of 80 students in five subjects in an examination. Calculate how many student offer Mathematics.

A. 50

B. 20

C. 30

D. 40

42. Find the mean of $t + 2$, $2t - 4$, $3t + 2$ and $2t$.

A. $2t + 1$

B. t

C. $t + 1$

D. $2t$

43. The mean of seven numbers is 10. If six of the numbers are 2, 4, 8, 14, 16 and 18, find the mode.

- A. 14
- B. 2
- C. 6
- D. 8

Age	20	25	30	35	40	45
No. of people	3	5	1	1	2	5

44. Calculate the median age of the frequency distribution in the table above

- A. 35
- B. 20
- C. 25
- D. 30

45. If the variance of $3 + \sqrt{6}, 4, 7 - \sqrt{4}$ and the mean is 5, find the standard deviation

- A. 3
- B. $\sqrt{2}$

C. $\sqrt{3}$

D. 2

Score	3	4	5	6	7	8	9	10
Freq.	1	0	7	5	2	3	1	1

46. The table above shows the scores of 20 students in further mathematics test. What is the range of the distribution?

- A. 3
- B. 10
- C. 7
- D. 6

47. In how many ways can a student select 2 subjects from 5 subjects?

- A. —
- B. —
- C. —
- D. —

48. In how many ways can 3 seats be occupied if 5 people are willing to sit?

- A. 5
- B. 120
- C. 60
- D. 20

49. What is the probability that an integer x ($1 \leq x \leq 25$) chosen at random is divisible by both 2 and 3?

- A. —
- B. -
- C. —
- D. -

50. A basket contains 9 apples, 8 bananas and 7 oranges. A fruit is picked from the basket, find the probability that it is neither an apple nor an orange.

- A. —
- B. -
- C. -
- D. -

ANSWERS

**1. D 2. B 3. A 4. C 5. C 6. B 7. B
8. C 9. C 10. B 11. B 12. D 13. D
14. A 15. D 16. A 17. B 18. C
19. A 20. D 21. C 22. D 23. D
24. D 25. B**

**26. B 27. B 28. D 29. B 30. A
31. D 32. C 33. C 34. D 35. B
36. B 37. B 38. B 39. D 40. D
41. D 42. D 43. D 44. C 45. D
46. C 47. A 48. C 49. A 50. C**

Facebook Study Group

If you need an **explanation** to any of the answers or you want to **download** more past questions for FREE.

Click to **ENTER** our Facebook study group



TYPE: S

1. Which Question Paper Type of Mathematics is given to you?

- A. Type F
- B. Type E
- C. Type L
- D. Type S

2. Find the value of $110111_2 + 10100_2$

- A. 1001111_2
- B. 1101011_2
- C. 100101_2
- D. 1001111_2

3. A woman bought a grinder for ₦60,000. She sold it at a loss of 15%. How much did she sell it?

- A. ₦50,000
- B. ₦53,000
- C. ₦52,000
- D. ₦51,000

4. Express the product of 0.00043 and 2000 in standard form.

- A. 8.6×10
- B. 8.3×10^{-3}
- C. 8.6×10^{-2}
- D. 8.6×10^{-1}

5. A man donates 10% of his monthly net earnings to his church. If it amounts to ₦4,500, what is his net monthly income?

- A. ₦62,500
- B. ₦40,500
- C. ₦45,000
- D. ₦52,500

6. If $\log 7.5 = 0.8751$, evaluate $2 \log 75 + \log 750$.

- A. 66.253
- B. 6.6252
- C. 6.6253
- D. 66.252

7. Solve for x in $8x^{-2} = _$

- A. 10
- B. 4
- C. 6
- D. 8

8. Simplify $\frac{\sqrt{6}}{\sqrt{6}}$

- A. $3\sqrt{6} + 1$
- B. $3\sqrt{6} - 7$
- C. $3\sqrt{6} + 7$
- D. $3\sqrt{6} - 1$

9. Evaluate $\log_2 8 + \log_2 16 - \log_2 4$

- A. 6
- B. 3
- C. 4
- D. 5

10. If $P = \{1,2,3,4,5\}$ and $P \cup Q = \{1,2,3,4,5,6,7\}$, list the elements in Q

- A. $\{5, 7\}$
- B. $\{6\}$
- C. $\{7\}$
- D. $\{6, 7\}$

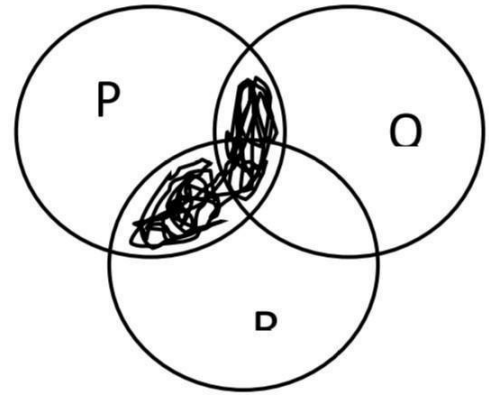

11. From the Venn diagram above, the shaded parts represent

- A. $(P \cap Q) \cap (P \cap D)$
- B. $(P \cap Q) \cup (P \cap D)$
- C. $(P \cup Q) \cap (P \cup D)$
- D. $(P \cup Q) \cup (P \cup D)$

12. If $gt^2 - k - w = 0$, make g the subject of the formula

- A. —
- B. —
- C. —
- D. —

13. Factorize $2y^2 - 15xy + 18x^2$

- A. $(3y + 2x)(y - 6x)$
- B. $(2y - 3x)(y + 6x)$
- C. $(2y - 3x)(y - 6x)$

D. $(2y + 3x)(y - 6x)$

14. Find the value of k if $y - 1$ is a factor of $y^3 + 4y^2 + ky - 6$

- A. 0
- B. -6
- C. -14
- D. 1

15. y varies directly as w . When $y = 8$, $w = 2$. Find y when $w = 3$

- A. 6
- B. 18
- C. 12
- D. 9

16. P varies directly as Q and inversely as R . When $Q = 36$ and $R = 16$, $P = 27$. Find the relation between P , Q and R .

- A. $P = \frac{QR}{12}$
- B. $P = \frac{QR}{18}$
- C. $P = \frac{QR}{24}$
- D. $P = 12QR$

17. What is the solution of $x^2 - 2x - 15 < 0$?

- A. $x < -3$ or $x > 5$
- B. $-3 < x < 5$
- C. $x < -3$ or $x > 1$
- D. $-3 < x < 1$

18. Evaluate the inequality $x^2 - 4x + 4 \leq 0$

- A. $x \geq -4$
- B. $x \geq 4$
- C. $x \leq 3$
- D. $x \geq -3$

19. The 4th term of an A.P. is 13 while the 10th term is 31. Find the 24th term.

- A. 69
- B. 89
- C. 75
- D. 73

20. What is the common ratio of the G.P. $(\sqrt{10} + \sqrt{5})(\sqrt{10} + 2\sqrt{5}) + \dots$?

- A. 5
- B. $\sqrt{2}$
- C. $\sqrt{5}$
- D. 3

21. A binary operation $*$ is defined by $x * y = xy$. If $x * 2 = 12 - x$, find the possible values of x

- A. -3, -
- B. 3, 4
- C. 3, -4
- D. -3, -

22. Find y , if _____

- A. 2
- B. 8
- C. 5
- D. 3

23. If _____ = -12, find x

- A. 6
- B. -6
- C. -2
- D. 3

24. Find the value of

- A. -2
- B. 12
- C. 10
- D. -1

25. How many sides has a regular polygon whose interior angle is 135° each?

- A. 8
- B. 12
- C. 10
- D. 9

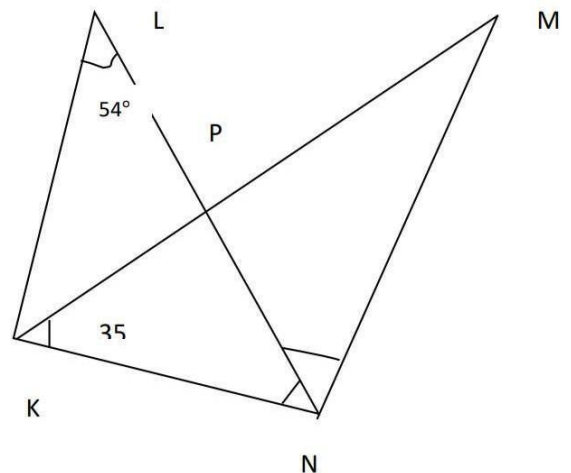

26. In the figure above, KLINM, LN bisects $\angle KNM$. If angles KLN is 54° and angle MKN is 35° , calculate the size of angle KMN.

- A. 19°
- B. 91°
- C. 89°
- D. 37°

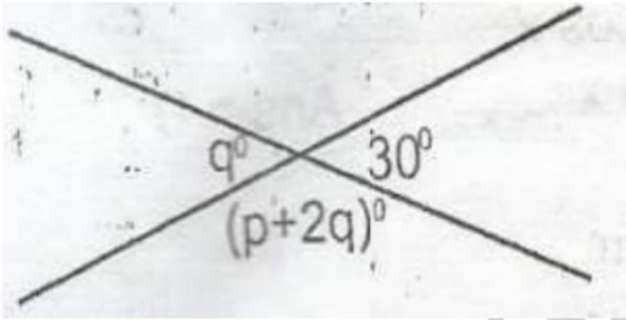

27. From the figure above, what is the value of p ?

- A. 135°
- B. 90°
- C. 60°
- D. 45°

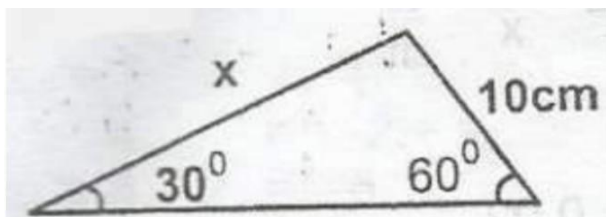

28. Find the value of x in the figure above

- A. $4\sqrt{3}$ cm
- B. $120\sqrt{3}$ cm
- C. $10\sqrt{3}$ cm
- D. $5\sqrt{3}$ cm

29. If the angle of a sector of a circle with radius 10.5 cm is 120° , find the perimeter of the sector.

- A. 2.5m
- B. 8.0m
- C. 7.5m
- D. 5.0m

30. A cylindrical tank has a capacity of 6160m^3 . What is the depth of the tank if the radius of its base is 28cm? [$\pi = -$

- A. 8.0m
- B. 7.5m
- C. 5.0m
- D. 2.5m

31. The locus of a dog tethered to a pole with a rope of 4m is a

- A. semi-circle with radius 4m
- B. circle with diameter 4m
- C. circle with radius 4m
- D. semi-circle with diameter 4m

32. Find the mid-point of $S(-5, 4)$ and $T(-3, -2)$

- A. 4, -1
- B. -4, 2
- C. 4, -2
- D. -4, 1

33. The gradient of a line joining (x,4) and (1,2) is . Find the value of x

- A. -5
- B. 5
- C. 3
- D. -3

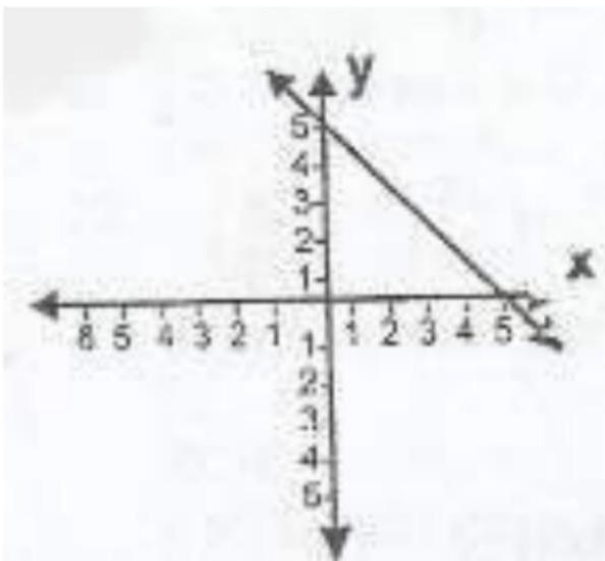

34. In the figure above, what is the equation of the line that passes the y-axis at (0,5) and passes the x-axis at (5,0)?

- A. $y = -x - 5$

- B. $y = x + 5$
- C. $y = -x + 5$
- D. $y = x - 5$

35. Calculate the mid-point of the line segment $y - 4x + 3 = 0$, which lies between the x-axis and y-axis.

- A. --
- B. --
- C. --
- D. --

36. Find the equation of the straight line through (-2, 3) and perpendicular to $4x + 3y - 5 = 0$

- A. $5x - 2y - 11 = 0$
- B. $3x - 4y + 18 = 0$
- C. $3x + 2y - 18 = 0$
- D. $4x + 5y + 3 = 0$

37. If $\sin \theta = \frac{3}{5}$, find the value of $1 + \cos \theta$

- A. —

B. —

C.

D. —

38. If $y = 4x^3 - 2x^2 + x$, find —

A. $12x^2 - 4x + 1$

B. $8x^2 - 2x + 1$

C. $8x^2 - 4x + 1$

D. $12x^2 - 2x + 1$

39. If $y = \cos 3x$, find —

A. $-3\sin 3$

B. $\sin 3$

C. $-\sin 3$

D. $3 \sin 3$

40. Find the minimum value of $y = x^2 - 2x - 3$

A. -4

B. 4

C. 1

D. -1

41. Evaluate $\int \sin 2x \, dx$

A. $-\cos 2 + k$

B. $\cos 2 + k$

C. $\cos 2 + k$

D. $-\cos 2 + k$

42. Evaluate $\int dx$

A. $-(2 + \dots + k$

B. $-(2 + 3)^6 + k$

C. $(2 + \dots + k$

D. $-(2 + \dots + k$



43. The pie chart above shows the monthly distribution of a man's salary on food items. If he spent ₦8,000 on rice, how much did he spend on yam?

- A. ₹42,000
- B. ₹18,000
- C. ₹16,000
- D. ₹12,000

44. The mean of $2 - 4$, $4 + t$, $3 - 2t$ and $t - 1$ is

- A. -2
- B. t
- C. $-t$
- D. 2

Values	0	1	2	3	4
Frequency	1	2	2	1	9

45. Find the mode of the distribution above

- A. 4
- B. 1
- C. 2
- D. 3

46. Find the median of 5, 9, 1, 10, 3, 8, 9, 2, 4, 5, 5, 5, 7, 3 and 6

- A. 3
- B. 6
- C. 5

D. 4

47. Find the standard deviation of 5, 4, 3, 2, 1

- A. $\sqrt{10}$
- B. $\sqrt{2}$
- C. $\sqrt{3}$
- D. $\sqrt{6}$

48. In how many ways can a team of 3 girls be selected from 7 girls?

- A. —
- B. —
- C. —
- D. —

Numbers	1	2	3	4	5	6
Frequency	18	22	20	16	10	14

49. The table above represents the outcome of throwing a die 100 times. What is the probability of obtaining at least a 4?

- A. —
- B. —

C. –

D. –

50. A number is chosen at random from 10 to 30 both inclusive. What is the probability that the number is divisible by 3?

A. –

B. —

C. —

D. –

ANSWERS

1. D 2. D 3. D 4. D 5. D 6. C 7. A

8. B 9. D 10. D 11. A 12. B 13. C

14. D 15. B 16. C 17. B 18. B

19. D 20. B 21. C 22. D 23. A

24. A 25. D

26. B 27. C 28. C 29. C 30. A

31. B 32. D 33. B 34. B 35. D

36. B 37. C 38. A 39. A 40. C

41. D 42. D 43. D 44. D 45. A

46. C 47. B 48. D 49. D 50. D

1. The sum of the progression is $1+x+x^2+\dots=$

- A. —
- B. —
- C. —
- D. —

2. Find a square root of $170-20\sqrt{30}$

- A. $2\sqrt{10} - 5$
- B. $3\sqrt{5} - 8\sqrt{6}$
- C. $2\sqrt{5} - 5\sqrt{6}$
- D. $5\sqrt{5} - 2\sqrt{6}$

3. Multiply $(x+3y + 5)$ by $(2x^2 + 5y + 2)$

- A. $2x^3 + 3yx^2 + 10xy + 15y^2 + 13y + 10x^2 + 2x + 10$
- B. $2x^3 + 6yx^2 + 5xy + 15y^2 + 31y + 10x^2 + 2x + 10$
- C. $2x^3 + 3yx^2 + 5xy + 10y^2 + 13y + 5x^2 + 2x + 10$
- D. $2x^3 + 6yx^2 + 5xy + 15y^2 + 13y + 10x^2 + 2x + 10$

4. A force of 5 units acts on a particle in the direction to the east and another force of 4 units

acts on the particle in the direction north-east. The resultant of the two forces is

- A. $\sqrt{3}$
- B. $3\sqrt{}$
- C. $\sqrt{41} + 20\sqrt{2}$
- D. $\sqrt{41} + 202$

5. Simplify $\frac{-}{-}$

- A.
- B.
- C.
- D.

6. In the diagram below PQ is parallel to RS, calculate the value of x

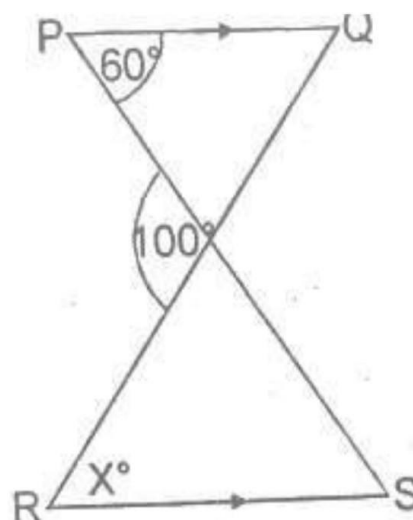

- A. 20°
- B. 40°
- C. 60°
- D. 80°

7. A ladder resting on a vertical wall makes an angle whose tangent is 2.4 with the ground. If the distance between the foot of the ladder and the wall is 50cm, what is the length of ladder?

- A. 1.3m
- B. 1.1m
- C. 1.2m
- D. 1.3m

8. After getting a rise of 15%, a man's new monthly salary is ₦345. How much per month did he earn before the increase?

- A. ₦350
- B. ₦396.75
- C. ₦300
- D. ₦293.25

9. A trader goes to Ghana for y days with Y cedis. For the first x

days, he spends X cedis per day. The amount he has to spend per day for the rest of his stay is

- A. $\frac{Y-X}{y-x}$ cedis
- B. $\frac{Y-X}{y}$
- C. $\frac{Y-X}{x}$
- D. $\frac{Y-X}{y-x}$

10. The mean of the numbers 1.2, 1.0, 0.4, 1.4, 0.8, 0.8, 1.2 and 1.1 is

- A. 1.5
- B. 0.8
- C. 1.0
- D. 1.05

11. A solid cylinder of radius 3cm has a total surface area of 36cm^2 . Find its height

- A. 2cm
- B. 3cm
- C. 4cm
- D. 5cm

12. When a dealer sells a bicycle for ₦81, he makes a profit of 8%. What did he pay for the bicycle?

- A. ₦75
- B. ₦74.52
- C. ₦75
- D. ₦75.52

13. Which of the formula below represents the general terms of the following set of numbers?

$\{-1, - , - , - , \dots\}$ for $n = 1, 2, 3, 4, \dots$

- A. —
- B. $(-)^{n+1}$ —
- C. $(-)$ —
- D. —

14. Write the decimal number 39 to base 2

- A. 100111
- B. 110111
- C. 111001
- D. 100101

15. A pentagon has four of its angles. If the size of the fifth angle is 60° . Find the size of each of the four equal angle is

- A. 60°
- B. 108°
- C. 120°
- D. 150°

16. In the figure below $PQ \parallel SR$, $ST \parallel RQ$, $PS = 7\text{cm}$, $PT = 7\text{cm}$, $SR = 4\text{cm}$. Find the ratio of the area of QRST to the area of PQRS

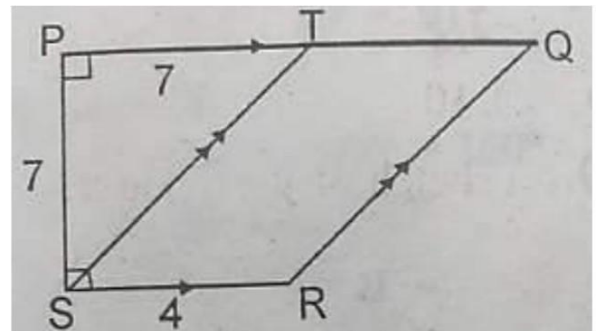

- A. 56:77
- B. 56:105
- C. 28:105
- D. 28:49

17. Find a two-digit number such that three times the ten digits is 2 less than twice the units digit and twice the units digit and twice the

number is 20 greater than the number obtained by reversing the digits.

- A. 24
- B. 42
- C. 74
- D. 47

18. In the figure above, the area of XYZW is

- A. 60 cm²
- B. 54 cm²
- C. 27 cm²
- D. 52.2 cm²

19. In ΔXYZ , $XY = 3$ cm, $XZ = 5$ cm and $YZ = 7$ cm. If the bisector of $\angle XYZ$ meets XZ at W , what is the length of XW ?

- A. 1.5 cm
- B. 2.5 cm
- C. 3 cm
- D. 4 cm

20. Marks scored by some children in an arithmetic test are

5, 3, 6, 9, 4, 7, 8, 6, 2, 7, 8, 4, 5, 2, 1, 0, 6, 9, 0, 8. The arithmetic mean of the marks is

- A. 6
- B. 5
- C. 7
- D. 4

21. The graphical methods of solving the equation $x^3 + 3x^2 + 4x - 28 = 0$ is by drawing the graphs of the curves

- A. $y = x^3$ and $y = 3x^2 + 4x - 48$
- B. $y = x^3 + 3x^2 + 4x - 28$ and the line $y = 1$
- C. $y = x^3 + 3x^2 + 4x$ and $y = 28$
- D. $y = x^2 + 3x + 4$ and $y = 28$

22. A sector of a circle is bounded by two radii 7 cm long and an arc of length 6 cm. Find the area of the sector.

- A. 42 cm²
- B. 3 cm²
- C. 21 cm²
- D. 24 cm²

23. Express 150 kilometres per second in metres per hour.

- A. 7.8×10^5
- B. 4.5×10^6
- C. 7,800,000
- D. 4.68×10^6

24. The arithmetic mean of the ages of 30 pupils in a class is 15.3 years. One boy leaves the class and one girl is enrolled, and the new average age of 30 pupils in the class becomes 15.2 years. How much older is the boy than the girl?

- A. 30 years
- B. 6 years
- C. 9 years
- D. 3 years

25. A world congress of mathematician was held in Nice in 1970 with 800 people participating. There were 300 from Europe, 200 from America, 150 from Asia, 45 from Africa and 105 from Australia.

Representing the above on a Pie Chart, the angle of the sector representing the participants from Asia is

- A. 150°
- B. 67.5°
- C. 67°
- D. 135°

26. Find the sum to infinity of the following sequence: $1, \frac{9}{10}, \frac{9}{10^2}, \frac{9}{10^3}$

- A. $\frac{1}{10}$
- B. $\frac{9}{10}$
- C. $\frac{10}{9}$
- D. 10

27. Which of the following is a sketch of $y = 3 \sin x$?

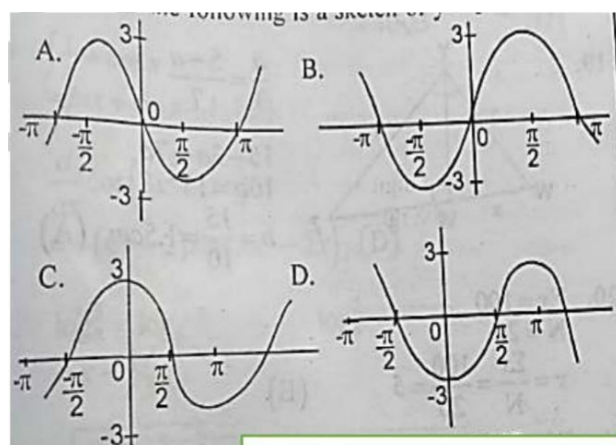

28. Given that $\log 2 = 0.693$ and $\log 3 = 1/097$, Find $\log 13.5$

- A. 1.404
- B. 1.790
- C. 2.598
- D. 2.790

29. If the function $() = x^3 + 2x^2 + x - 6$ is divisible by the factor $x+1$, find q .

- A. -5
- B. -2
- C. 2
- D. 5

30. What value of g will make the expression $4x^2 - 18xy + y^2 + g$ a perfect square?

- A. 9
- B. —
- C. 81^2
- D. —

31. An arc of a circle subtends an angle 70° at the centre. If the radius of the circle is 6cm,

calculate the area of the sector subtended by the given angle.

- A. 22 cm²
- B. 44 cm²
- C. 66 cm²
- D. 88 cm²

32. The angle of elevation of a building from a measuring instrument placed on the ground is 30° . If the building is 40m high, how far is the instrument from the foot of the building?

- A. $\frac{40}{3}$
- B. $\frac{40}{\sqrt{3}}$
- C. $20\sqrt{3}$ m
- D. $40\sqrt{3}$

33. Integrate $\frac{1}{x} + \cos x$ with respect to x

- A. $-\frac{1}{x} + \sin x + k$
- B. $\frac{1}{x} + \sin x + k$
- C. $\ln x - \sin x + k$
- D. $-\frac{1}{8} \sin x + k$

34. $\cos(3^2 - 2)$ is equal to

- A. $-\sin(6 - 2)$
- B. $-\sin(3^2 - 2)$
- C. $(6x-2) \sin(3^2 - 2)$
- D. $-(6x-2) \sin(3^2 - 2)$

35. If $\log_8 10 = x$, evaluate $\log_8 5$ in terms of x .

- A. $1/2x$
- B. $-1/4$
- C. $x - 1/3$
- D. $x - 1/2$

36. Simplify $\frac{\quad}{\quad}$

- A. 15
- B. 20
- C. 40
- D. 75

37. Find the matrix **T** if **ST = I** where $S = \begin{pmatrix} \quad & \quad \\ \quad & \quad \end{pmatrix}$ and **I** is the identity matrix

A.

- B.
- C.
- D.

38. The first term of a geometrical progression is twice its common ratio. Find the sum of the first two terms of the progression if its sum to infinity is 8.

- A. $8/5$
- B. $8/3$
- C. $72/25$
- D. $56/9$

39. In ΔMNO , **MN** = 6 units, **MO** = 4 units and **NO** = 12 units. If the bisector of angle M meets **NO** at **P**, calculate **NP**.

- A. 4.8 units
- B. 7.2 units
- C. 8.0 units
- D. 18.0 units

40. Evaluate $\int (\sin - \cos)$

- A. $\sqrt{2} + 1$

- B. $\sqrt{2} - 1$
C. $-\sqrt{2} - 1$
D. $-\sqrt{2}$

ANSWERS

1. A 2. C 3. B 4. C 5. D 6. B 7. D
8. C 9. D 10. C 11. C 12. B 13. C
14. A 15. C 16. B 17. D 18. C
19. A 20. B

21. D 22. C 23. D 24. D 25. B
26. D 27. D 28. C 29. A 30. D
31. A 32. D 33. B 34. D 35. C
36. B 37. C 38. B 39. B 40. B

Facebook Study Group

If you need an **explanation** to any of the answers or you want to **download** more past questions for FREE.

Click to **ENTER** our Facebook study group



1. Without using tables, evaluate

$$\log_2 4 + \log_4 2 - \log_{25} 5$$

- A. 1/2
- B. 1/5
- C. 0
- D. 2

2. Find the values of p for which

the equation $x^2 - (p-2)x + 2p + 1 = 0$ has equal roots.

- A. (0, 12)
- B. (1, 2)
- C. (21, 0)
- D. (4, 5)

3. Solve the simultaneous

equation $2x - 3y = 10, 10x - 6y = 5$

- A. $x = 2, y = 3$
- B. $x = 3, y = 2$
- C. $x = 2, y = 3$
- D. $x = 3, y = 2$

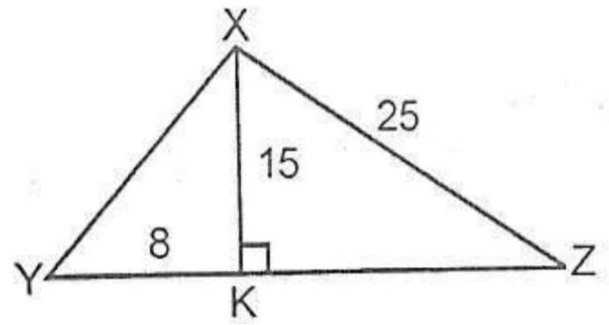

4. In ΔXYZ above, $\angle X = 90^\circ$,
 $YK = 8$, $XK = 15$, $XZ = 25$

8. Find the area of ΔXYZ .

- A. 180 sq.cm
- B. 20sq cm
- C. 160sq. cm
- D. 320 sq.cm

5. Simplify $3 - 1 \times +_1$

- A. 2
- B. 3
- C. 4
- D. 4

6. Factorize $1 - (-)^2$

- A. $(1 - -)(1 - +)$
- B. $(1 - +)(1 + -)$
- C. $(1 - +)(1 - +)$
- D. $(1 - -)(1 + -)$

7. Find the range of value of x which satisfy the inequality

$$-x - 3 < 1$$

A. $x < -4$

B. $x < 13$

C. $x < 3$

D. $x < -1$

8. A crate of soft drinks contains 10 bottles of Cococola, 8 of Fanta and 6 of Sprite, if one bottle is selected at random, what is the probability that it is NOT a Coca-Cola bottle?

A. $5/12$

B. $1/3$

C. $3/4$

D. $7/12$

9. The gradient of curve is $2x + 1$ and the curve passes through point $(2, 0)$. Find the equation of the curve.

A. $y = x^2 + 7x + 9$

B. $y = x^2 + 7x - 18$

C. $y = x^2 + 7x + 9$

D. $y = x^2 + 14x + 11$

10. Differentiate $(\cos q - \sin q)^2$ with respect to q .

A. $-2 \cos 2q$

B. $-2 \sin 2q$

C. $1 - 2 \cos 2q$

D. $1 - 2 \sin 2q$

11. If $\tan \theta = 5/4$, find $\sin^2 \theta - \cos^2 \theta$.

A. $5/4$

B. $41/9$

C. $9/41$

D. 1

12. Find the value of x if the expression $x^2 + 5x - 2$ leaves a remainder 2 when it is divided by $x + 1$.

A. 10

B. 8

C. -10

D. -8

13. If $y = x^2 - x - 12$, find the range of values of x for which $y \geq 0$.

- A. $x < -2$ and $x > 4$
- B. $x \leq -3$ and $x \geq 4$
- C. $-3 < x \leq 4$
- D. $-3 \leq x \leq 4$

14. A man bought a second-hand photocopying machine for ₦34 000. He served it at a cost of ₦2,000 and then sold it at a profit of 15%. What was the selling price?

- A. ₦37,550
- B. ₦40,400
- C. ₦41,400
- D. ₦42,400

15. Find the radius of a sphere whose surface area is 154π cm².

- A. 7.00 cm
- B. 3.50 cm
- C. 3.00 cm
- D. 1.75cm

16. The sum of the first n terms of the arithmetic progression 5, 11, 17, 23, 29, 35,... is

- A. $(3n^2 - 0)$
- B. $(3n^2 + 2n)$
- C. $(3n^2 + 2.5n)$
- D. $(3n^2 + 5n)$

17. What value of x will make the function $(4 - x^2)$ a maximum?

- A. 4
- B. 3
- C. 2
- D. 1

18. In how many ways can a delegation of 3 be chosen from 5 men and 3 women, if at least 1 man and 1 woman must be included?

- A. 15
- B. 28
- C. 30
- D. 45

19. The table above shows the distribution of marks of students in an test. Find the probability of passing the test if the pass mark is 5

- A. $\frac{3}{5}$
- B. $\frac{4}{9}$
- C. $\frac{7}{20}$
- D. $-\frac{1}{5}$

20. A student measures a piece of rope and found that it was 1.26m long. If the actual length of the rope was 1.24 m, what was the percentage error in the measurement?

- A. 0.40%
- B. 0.01%
- C. 0.25%
- D. 0.80%

21. Rationalize $\frac{\sqrt{15}}{\sqrt{15} + 11}$

- A. $\frac{\sqrt{15}}{\sqrt{15} + 11}$
- B. $\frac{\sqrt{15}}{\sqrt{15} - 11}$
- C. $3\sqrt{15} - 11$

D. $3\sqrt{15} + 11$

22. Solve the inequalities $-6 \leq 4 - 2 < 5 -$

- A. $-1 \leq < 6$
- B. $-1 < \leq 5$
- C. $-1 < < 5$
- D. $-1 \leq \leq 6$

23. A cylindrical pipe 5cm long with radius 7m has one end open. What is the total surface area of the pipe?

- A. 100π
- B. 98π
- C. 350π
- D. 749π

24. Find the standard deviation of 2, 3, 5 and 6

- A. $\sqrt{5/2}$
- B. $\sqrt{10}$
- C. $\sqrt{6}$
- D. $\sqrt{2/5}$

25. Without using tables evaluate
 $(343)^{-1/3} \times (0.14) - 1 \times (25)^{-1/2}$

- A. 10
- B. 12
- C. 8
- D. 7

26. Given that $\log_4 (x - 1) + \log_4 (1/2) = 1$
 $\log_2 (x + 1) + \log_2 y = 2$, solve for x and y respectively.

- A. 2, 3
- B. 3, 2
- C. -2, -3
- D. -3, -2

27. When the expression $2x^2 + px + 1$ is divided by $(x-1)$, it has a remainder 2 and when divided by $(x+1)$ the remainder is 4. Find p and q respectively.

- A. 2, -1
- B. -1, 2
- C. 3, -2
- D. -2, 3

28. Divide $2^3 + 11^2 + 17 + 6$
 $2 + 1$

- A. $2^2 + 5 + 6$
- B. $2^2 + 5 + 6$
- C. $2^2 - 5 + 6$
- D. $2^2 - 5 + 6$

⊗	p	q	r	S
p	r	p	r	P
q	p	q	r	S
r	r	r	r	R
s	q	s	r	Q

29. The identity element with respect to the element shown in the table above is

- A. p
- B. q
- C. r
- D. s

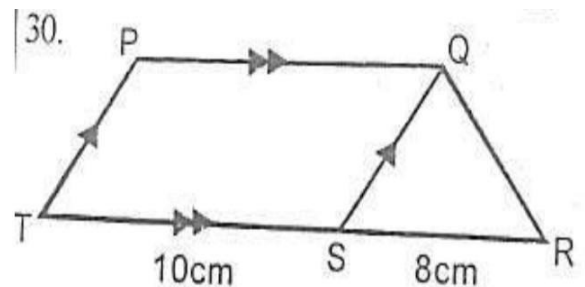

30. In the figure above, PQST is a parallelogram and TSR is a straight line. If the area of ΔQRS

is 20^2 , find the area of the trapezium PQRT

- A. 35^2
- B. 65^2
- C. 70^2
- D. 140^2

31. The mid-point of the segment of the line $x = 12 \times 15$ which lies between the x-axis and y-axis is

- A. $(- ,)$
- B. $(- ,)$
- C. $(-,)$
- D. $(-,)$

32. Find the equation of the curve which passes through the point $(2, 5)$ and whose gradient at any point is given by $6 - 5$

- A. $6^2 - 5$
- B. $6^2 + 5 + 5$
- C. $3^2 - 5 - 5$
- D. $3^2 - 5 + 3$

33. $\frac{1}{x} = x \times 10^h$

< 10 hThe value of are

- A. 7.381 and -11
- B. 2.34 and 10
- C. 3.871 and 2
- D. 7.831 and -11

34. Thirty boys and x girls sat for a test. The mean of the boys' scores and that of the girls were respectively 6 and 8. Find if the total score was 468.

- A. 38
- B. 24
- C. 36
- D. 22

35. Rationalize $\frac{1}{\sqrt{35}}$

- A. $-2\sqrt{35}$
- B. $\sqrt{7} - 6\sqrt{5}$
- C. $-\sqrt{35}$
- D. $4\sqrt{7}$

36. If $2 + 3 = 1 - 2 = 11, (+)$

- A. 5
- B. -3
- C. 8
- D. 2

37. A car dealer bought a second-hand car for ₦250,000.00 and spent ₦70,000.00 refurbishing it. He then sold the car for ₦400,000.00. What is the percentage gain?

38. Simplify _____

- A. 80
- B. 40
- C. $\frac{1}{40}$
- D. $\frac{1}{80}$

39. Find the value of p if the line joining $(p, 4)$ and $(6, -2)$ is perpendicular to the line joining $(2, p)$ and $(-1, 3)$

- A. 0
- B. 3
- C. 4
- D. 6

40. Find the number of sides of a regular polygon whose interior angle is twice the exterior angle.

- A. 2
- B. 3
- C. 6
- D. 8

ANSWERS

- 1. A 2. A 3. A 4. B 5. B 6. B 7. A
8. D 9. C 10. A 11. A 12. C 13. B
14. C 15. B 16. B 17. C 18. D
19. A 20. A
21. A 22. B 23. D 24. A 25. A
26. C 27. A 28. A 29. C 30. C
31. B 32. D 33. A 34. C 35. C
36. D 37. B 38. C 39. B 40. C**

1. If $2 - 3 = 3h$
 $= 0,$

- A. $2^2 - 3$
- B. $2 - 3$
- C. $2 - 3 - 3$
- D. $2 - 3 + 3$

2. If $P =$ and I is a 2×2 -
 unit matrix. Evaluate $2^2 - 2 +$
 41

- A.
- B.
- C.
- D.

3. Find the value of x if the line $2x - y + 4 = 0$ is perpendicular to
 the line $x - y - 1 = 0$

- A. -4
- B. 4
- C. 8
- D. -8

4. Calculate the mean deviation of
 the sets of numbers $7, 3, 14, 9, 7$
 and $8.$

- A. $2-$
- B. $2-$
- C. $1-$
- D. $2-$

5. The graph of the function $y = x^2 + 4$ and a straight-line PQ are
 drawn to solve the equation $x^2 - 3x + 2 = 0$. What is the equation
 $PQ?$

- A. $y = 3 - 2$
- B. $y = 3 + 2$
- C. $y = 3 - 4$
- D. $y = 3 + 4$

6. If $-\frac{1}{2} \leq x < 2, h$
 $f(x) =$ _____

- A. 4
- B. 1
- C. $2/3$
- D. $1/3$

7. On a pie chart, there are four scores of which three angles are 45° , 90° and 35° , if the smallest sector represents ₦28.00, how much is the largest sector?

- A. ₦96.00
- B. ₦84.00
- C. ₦48.00
- D. ₦42.00

8. The result of missing a fair dice 120 times is summarize is above, find the value of x

- A. 19
- B. 20
- C. 21
- D. 22

9. Given $\mu = \{ \begin{matrix} 0 & 30 \end{matrix} \}$

$P = \{ \begin{matrix} 6 & 0 \\ 30 \end{matrix} \}$

$Q = \{ \begin{matrix} 4 & 0 \\ 30 \end{matrix} \}$

Find (PUQ)

- A. {2, 10, 14, 22, 26}

B. {2, 10, 14, 22, 26}

C. {2, 4, 14, 18, 26}

D. {0, 2, 6, 22, 26}

$$\begin{array}{r}
 10. \quad \begin{array}{cccc} 4 & 2 & 4 & 3 \\ -1 & 3 & & 4 \\ \hline Y & 3 & 4 & 4 \\ \hline \end{array}
 \end{array}$$

Find x and y respectively in the subtraction above carried out in base 5.

- A. 2, 4
- B. 3, 2
- C. 4, 2
- D. 4, 3

11. Factorise completely $x^2 - 2(x - 2 + 4^2)$

- A. $(x - 2)(x + 2)$
- B. $(x - 2)(x - 2)$
- C. $(x - 2)(x - 2)$
- D. $(x - 2)(x + 2)$

12. PQRSTN is a regular polygon of side 7cm. Inscribed in a circle,

find the circumference of the circle PQRSTV

- A. 12cm
- B. 42cm
- C. 44cm
- D. 56cm

13. The shadow of a pole $5\sqrt{3}$ high is 5.5cm. Find the angle of elevation of the sun.

- A. 50
- B. 45
- C. 60
- D. 75

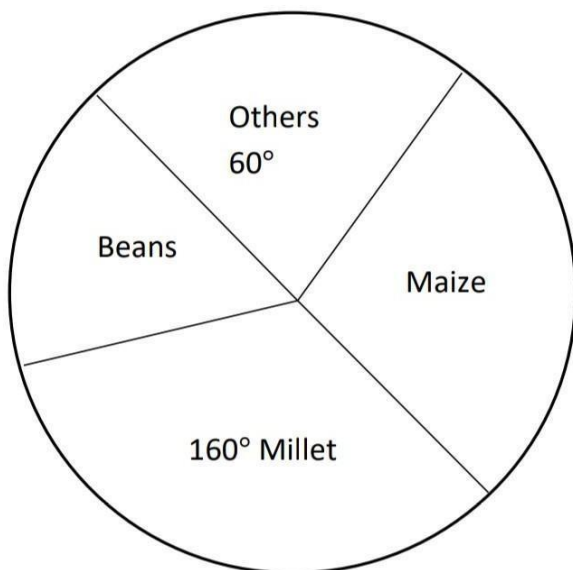

14. The pie chart above shows the distribution of the crops harvested from a farmland in a year. If 3000

tonnes of millet is harvested, what amount of beans is harvested?

- A. 9000 tonnes
- B. 6000 tonnes
- C. 1500 tonnes
- D. 1200 tonnes

15. A container has 30 gold medals, 22 silver medals and 18 bronze medals. If one medal is selected at random from the container, what is the probability that it is not a gold medal?

- A. $\frac{4}{7}$
- B. $\frac{3}{7}$
- C. $\frac{11}{35}$
- D. $\frac{9}{35}$

16. A polynomial in x whose zeros are $-2, -1, 3$

- A. $x^3 - 7x + 6$
- B. $x^3 + 7x - 6$
- C. $x^3 + 7x + 6$
- D. $x^3 - 7x - 6$

17. If M and N are two matrices defined by $M = \begin{pmatrix} 2 & 3 \\ 1 & 4 \end{pmatrix}$ and $N = \begin{pmatrix} 1 & 2 \\ 3 & 4 \end{pmatrix}$.

Evaluate $2M - 3N$.

- A.
- B.
- C.
- D.

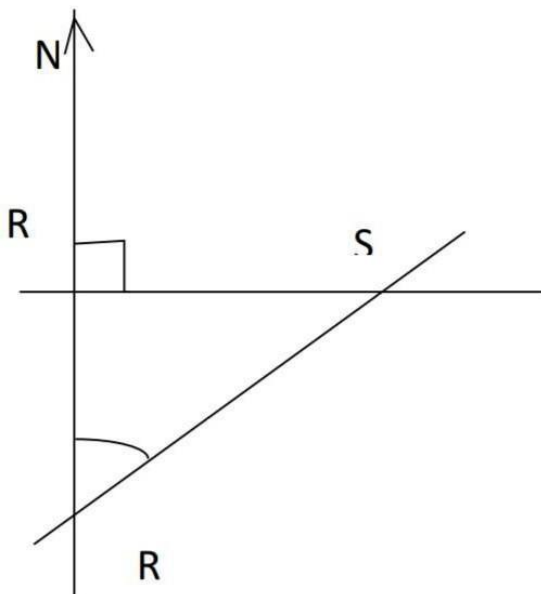

18. From the diagram above, find the bearing of **R** from **S**.

- A. 226°
- B. 224°
- C. 136°
- D. 134°

19. The mean height and range of heights 1.35, 1.25, 1.35, 1.40, 1.35, 1.45, 1.50, 1.35, 1.50 and 1.20 are m and r respectively. Find $m + 2r$.

- A. 1.35
- B. 1.65
- C. 1.95
- D. 3.00

20. What is the probability that an integer x , $\{1 \leq x \leq 20\}$ chosen at random is divisible by both 2 and 3?

- A. $1/20$
- B. $1/3$
- C. $3/20$
- D. $7/20$

21. A trader bought goats for ₦4000 each. He sold them for ₦4500 each. Find his profit percentage.

₦180,000 at a loss of 25%. How many goats did he buy?

- A. 60
- B. 50
- C. 45
- D. 36

22. Evaluate _____

- A. 0.01286
- B. 0.01285
- C. 0.1286
- D. 0.1285

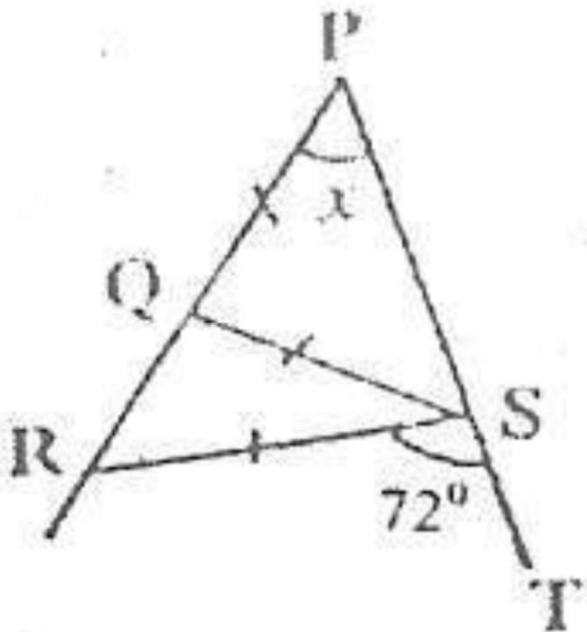

23. In the diagram above, **PST** is a straight line, **PQ = QS = RS**. If $\angle RST = 72^\circ$, find

- A. 36°
- B. 18°
- C. 72°
- D. 24°

24. If $\tan \theta = 4/3$, calculate $2 - 2$

- A. 16/25
- B. 24/25
- C. 7/25
- D. 9/25

25. If $N =$ _____ find $| |$

- A. 17
- B. 23
- C. 65
- D. 91

26. A man invested ₦5,000 for 9 months at 4%. What is the simple interest?

- A. ₦150
- B. ₦220
- C. ₦130
- D. ₦250

27. Rationalize $\frac{1}{\sqrt{2}}$

- A. $\frac{\sqrt{2}}{2}$
- B. $\frac{1}{2}$
- C. $\frac{2}{\sqrt{2}}$
- D. $\frac{1}{\sqrt{2}}$

28. Factorize completely $9^2 - 16^2$

- A. $(3 - 2)(3 + 4)$
- B. $(3 + 4)(3 + 4)$
- C. $(3 + 2)(3 - 4)$
- D. $(3 + 4)(3 - 4)$

29. Solve the inequalities $x^2 + 2x > 15$.

- A. $x < -3$ and $x > 5$
- B. $-5 < x < 3$
- C. $x < 3$ and $x > 5$
- D. $x > 3$ and $x < -5$

30. A circle of perimeter 28cm is opened to form a square. What is the maximum possible area of the square?

- A. 56 cm²
- B. 49 cm²
- C. 98 cm²
- D. 28 cm²

31. If two graphs $y = x^2 + 2x + 1$ and $y = x^2 - 1$ intersect at $x = 2$. Find the value of y in terms of x ?

- A. $y = x^2 + 2x + 1$
- B. $y = x^2 - 1$
- C. $y = x^2 + 1$
- D. $y = x^2 - 2x + 1$

32. A straight line makes an angle of 30° with the positive x -axis and the y -intercept is 5 . Find the equation of the straight line.

- A. $y = \sqrt{3}x + 5\sqrt{3}$
- B. $y = \sqrt{3}x - 5\sqrt{3}$
- C. $y = x + 5$
- D. $y = x + 5$

33. Find the area bounded by the curves $y = 4 - x^2$ and $y = x^2 + 1$.

- A. 10 sq. units

- B. 10- sq. units
- C. 20- sq. units
- D. 20- sq. units

34. Teams **P** and **Q** are involved in a game of football. What is the probability that game ends in a draw?

- A. $1/4$
- B. $1/3$
- C. $1/2$
- D. $2/3$

35. Find without using a logarithm table the value of $\frac{-}{-}$

- A. $7/4$
- B. $- 7/4$
- C. $-3/2$
- D. $7/3$

36. In the figure below, determine the angle marked .

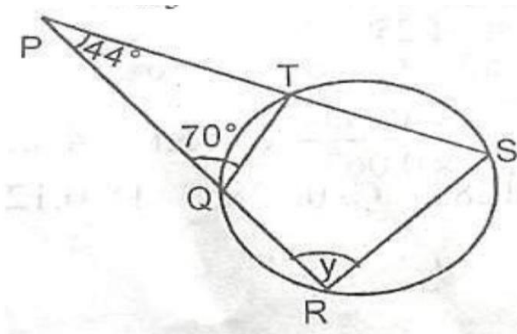

- A. 66°
- B. 110°
- C. 26°
- D. 70°

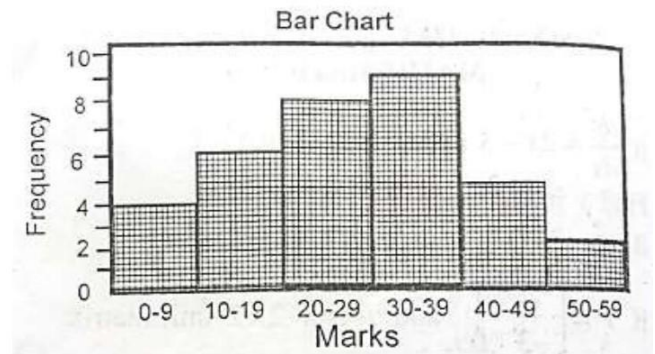

37. The bar chart above shows the mark distribution in a class test. Find the number of students in the class

- A. 9
- B. 2
- C. 60
- D. 30

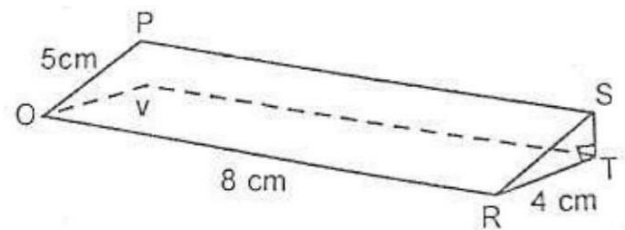

38. What is the volume of the regular three dimensional figure drawn above?

- A. 160 cm^3

- B. 48 cm³
- C. 96 cm³
- D. 120 cm³

39. Find the remainder when $2^3 - 2^2 + 3 - 3$ is divided by $2^2 + 1$.

- A. $2 - 1$
- B. $+ 3$
- C. $2 + 1$
- D. $- 3$

40. In a class of 60 students, 30 offer physics and 40 offer Chemistry. If a student is picked at random from the class, what is the probability that the student offers both physics and Chemistry?

- A. $1/3$
- B. $1/4$
- C. $1/2$
- D. $1/6$

ANSWERS

- 1. A 2. C 3. C 4. B 5. C 6. B 7. B**
8. B 9. A 10. C 11. C 12. B 13. C

- 14. D 15. A 16. D 17. C 18. B**
19. C 20. C

- 21. A 22. A 23. A 24. C 25. A**
26. A 27. B 28. D 29. B 30. B
31. D 32. A 33. B 34. C 35. C
36. D 37. D 38. B 39. A 40. A

Facebook Study Group

If you need an **explanation** to any of the answers or you want to **download** more past questions for FREE.

Click to **ENTER** our Facebook study group



$$\begin{array}{r}
 1. \quad 4 \quad 2 \quad 4 \quad 3 \\
 \quad -1 \quad 3 \quad \quad 4 \\
 \hline
 \quad Y \quad 3 \quad 4 \quad 4
 \end{array}$$

Find the _____ respectively in the subtraction above

- A. 2, 4
- B. 3, 2
- C. 4, 2
- D. 4, 3

2. Express the product of 0.00043 in Standard form

- A. 8.6×10
- B. 8.6×10^{-3}
- C. 8.6×10^{-2}
- D. 8.6×10^{-1}

3. Simplify $\frac{\sqrt{6}-\sqrt{6}}{\sqrt{6}-\sqrt{6}}$

- A. $5\sqrt{6} + 1$
- B. $3\sqrt{6} - 7$
- C. $3\sqrt{6} + 7$
- D. $3\sqrt{6} - 1$

4. If $g^2 - 4g - 4 = 0$ make g the subject of the formula

- A. _____
- B. _____
- C. _____
- D. _____

5. Find the value of $1 - \sqrt{2 + 4^2 + 4} - 6$

- A. 0
- B. -6
- C. -4
- D. 1

6. Find x if $\frac{1}{x} = \frac{1}{2} + \frac{1}{3}$

- A. 2
- B. 8
- C. 5
- D. 3

7. In the figure below **KL//NM**, **LN** bisects $\angle KNM$ if the angle **KLN** is 54° and angle **MLN** is 35° .

Calculate
the size
of angle
KMN

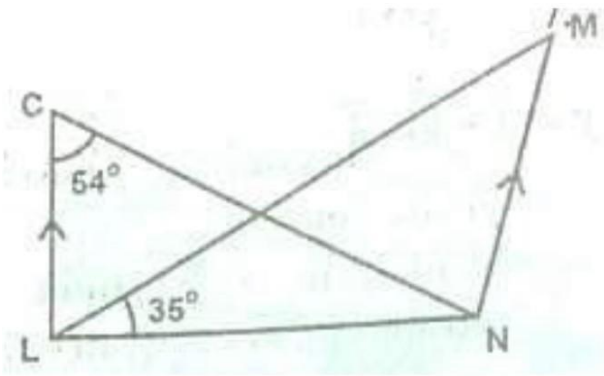

- A. 108°
- B. 91°
- C. 84°
- D. 37°

8. If the angle of a sector of a circle with radius of 10.5cm is 100. Find the perimeter of the sector.

- A. 2.5 m
- B. 3.0 m
- C. 7.5 m
- D. 5.0 m

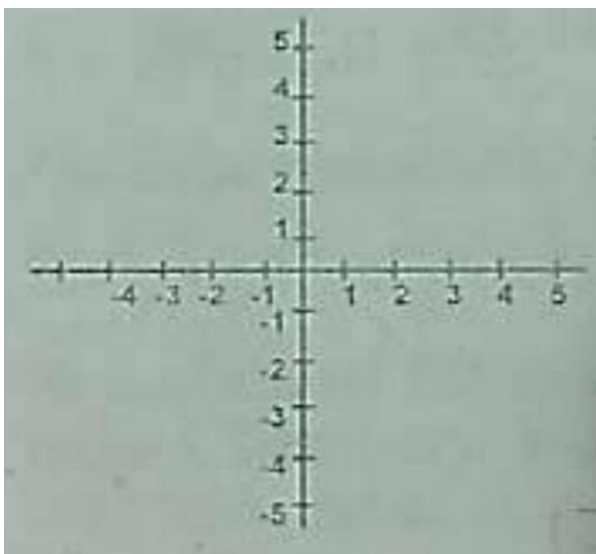

9. In the figure above, what is the equation of the line that passes the $(0, 5)$ and passes the $(5, 0)$

- A. $y = -x - 5$
- B. $y = -x + 5$
- C. $y = x + 5$
- D. $y = x - 5$

10. A construction company is owned by two partners and it is agreed that their profit will be divided in the ratio 4:5 at the end of the received ₦5,000 more than x. What is the total profit of the company per year?

- A. ₦20,000
- B. ₦25,000
- C. ₦50,000
- D. ₦45,000

11. If $x = 1$ is a root of the equation $x^3 - 2x^2 - 5x + 6 = 0$. Find the other roots

- A. -3 and 2

- B. -2 and 2
- C. 3 and -2
- D. 1 and 3

12. If $x + 2$ and $x - 1$ are factors of the expression $x^3 + 2x^2 + 24$. Find the value of

- A. $x = -6, y = -2$
- B. $x = -2, y = 1$
- C. $x = -2, y = -1$
- D. $x = 0, y = -1$

13. Simplify $\frac{x^2 - 4}{x^2 - 2x}$

- A. $\frac{x+2}{x}$
- B. $\frac{x-2}{x}$
- C. $\frac{x+2}{x-2}$
- D. $\frac{x-2}{x-1}$

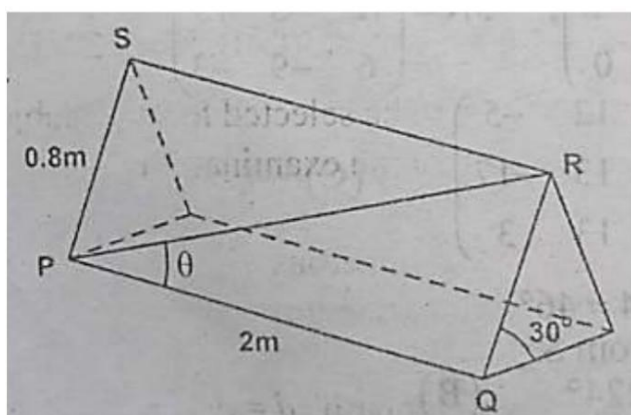

14. PQRS is a desk of dimension $2m \times 0.8m$ which is inclined at 30° to the horizontal

- A. $25^\circ, 35'$
- B. 30°
- C. $15^\circ, 36'$
- D. 10°

15. Find the missing point/value in the following road

X	-2	-1	0	1	2	3
$Y = x^3 - x + 3$		3	3	3	9	27

- A. -5
- B. 3
- C. -9
- D. 13

16. Correct each of the following 59.81798 and 0.0746829 to three significant figures and multiply them giving your answer to three significant figures.

- A. 4.46
- B. 4.48
- C. 4.47
- D. 4.49

17. One interior angle of a convex of hexagon is 170° and each of the remaining angles is equal to $^\circ$. Find .

- A. 120°
- B. 110°
- C. 105°
- D. 102°

18. If $() = \text{---} + \dots\dots\dots$ Find $(1-)$

- A. $-\text{---}$
- B. $+\text{---}$
- C. $-\text{---}$
- D. $-\text{---}$

19. Convert 241_5 to base 8

- A. 71_8
- B. 107_8
- C. 176_8
- D. 241_8

20. A train moves from P at Q at an average speed of 40km/hr and immediately returns from Q is P

through the 45km/hr. Find the average speed for the entire journey

- A. 55 /h
- B. 50 /h
- C. 67.50 /h
- D. 75 /h

21. By selling 20 oranges for ₦1.35 a trader makes a profit of ₦82. Which is his percentage gain or loss if he sells the same 20 oranges for ₦1.10?

- A. 8%
- B. 10%
- C. 12%
- D. 15%

22. Simplify without using tables

$$\frac{\text{---}}{\text{---}}$$

- A. $\frac{\text{---}}{\text{---}}$
- B. $\frac{\text{---}}{\text{---}}$
- C. $\frac{\text{---}}{\text{---}}$
- D. $\frac{\text{---}}{\text{---}}$

23. Make y the subject of the formula $Z = 2 + \underline{\quad}$?

A. $= \underline{\quad}$

B. $= \underline{\quad}$

C. $= \underline{\quad}$

D. $= \underline{\quad}$

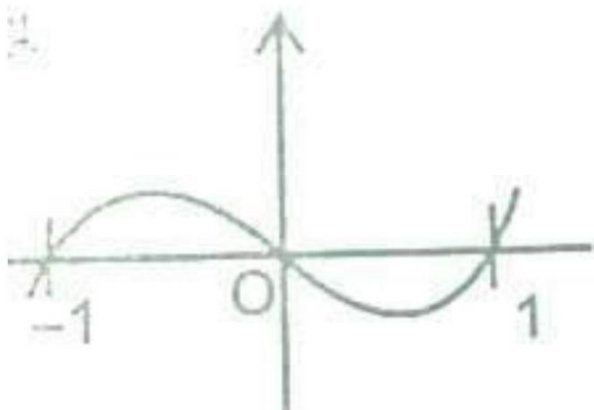

24. A cubic function () is specified by the graph shown above. The values of the independent variable for which the function $x \dots$

A. $-1, 0, 1$

B. $-1 \leq \leq 1$

C. < -1

D. > 1

25. Find the eleventh term of the progression 4, 8, 16, ...

A. 2^{13}

B. 2^{12}

C. 2^{11}

D. 2^{16}

26. The histogram above represents the weight of students who travelled out of their schools for an examination. How many people made the trip?

A. 78

B. 58

C. 29

D. 69

27. In the many ways can 6 subjects be selected from 10 subject be selected from 10 subjects for an examination?

A. 218

B. 216

C. 215

D. 210

28. Find the value of x which the functions () $= 2^2 - 2 - 4 + 4$ has a maximum value

- A. $\frac{2}{3}$
- B. 1
- C. $-\frac{2}{3}$
- D. -1

29. Make L the subject of the formula if = $\frac{L}{L+1}$

- A. $\frac{L}{L+1}$
- B. $\frac{L+1}{L}$
- C. $\frac{L+1}{L-1}$
- D. $\frac{L-1}{L+1}$

30. Calculate the simple interest on ₦1,500 for 8 years at 5% per annum

- A. ₦5,000
- B. ₦600
- C. ₦500
- D. ₦150

31. Solve the quadratic inequality $x^2 - 5x + 6 \geq 0$

- A. $x \leq 2, x \geq 7$

- B. $x \leq 3, x \geq 2$
- C. $x \leq -2, x \geq -3$
- D. $x \leq -3, x \geq 2$

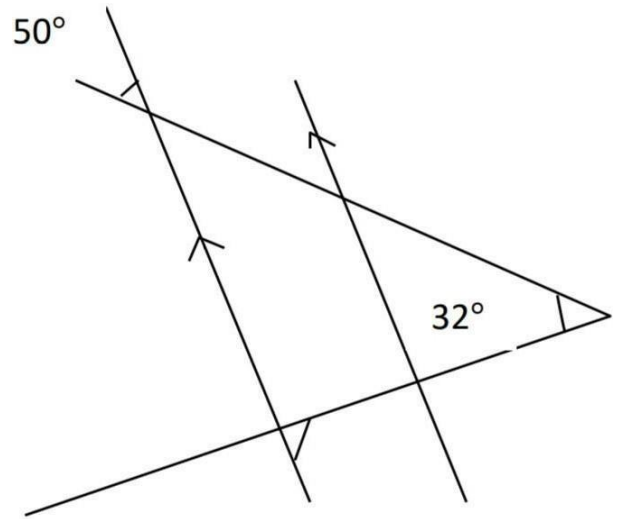

32. In the diagram above $PQ \parallel RS$, The size of the angle marked x is

- A. 100°
- B. 80°
- C. 50°
- D. 30°

33. Find the gradient of a line which is perpendicular to the line with equation $3x + 2y + 1 = 1$

- A. $\frac{3}{2}$
- B. $-\frac{2}{3}$
- C. $-\frac{2}{5}$
- D. $-\frac{3}{2}$

34. Evaluate $\frac{1}{2} - \frac{1}{3}$

- A. 0
- B. 1
- C. 2
- D. 3

35. If the lines $3x = 4y - 1$ and $4x = 3y + 3$ are parallel to each other, the value of is

- A. $-\frac{4}{3}$
- B. $-\frac{5}{4}$
- C. $\frac{4}{5}$
- D. $\frac{3}{4}$

36. The volume of a hemispherical bowl is $\frac{32\pi}{3}$ cm³, find its radius

- A. 4.0 cm
- B. 5.6cm
- C. 7.0cm
- D. 3.6cm

37. If $124_5 = 124_{10} + x$, find x .

- A. 124

- B. 121
- C. 181
- D. 180

38. A baking recipe calls for 2.5kg of sugar and 4.5kg of flour. With this recipe some cakes were baked using 24.5kg of a mixture of sugar and flour. How much sugar were used?

- A. 12.25kg
- B. 6.75kg
- C. 8.75kg
- D. 15.75kg

39. Two cars start at the same point and travel towards a point P which is 150 km away. If the average speed of y is 60 km per hour and x arrives 25 minutes earlier than y. what is the average speed of x?

- A. 51 km/h
- B. 72 km/h
- C. 66 km/h
- D. 37 km/h

40. The first term of an Arithmetic Progression is 3 and the fifth term is . Find the number of terms in the progression if the 5th term of the terms is 81?

- A. 12
- B. 27
- C. 9

ANSWERS

- 1. C 2. D 3. B 4. B 5. D 6. C 7. D**
8. – 9. C 10. D 11. C 12. B 13. D
14. D 15. A 16. C 17. B 18. C
19. B 20. D
- 21. B 22. C 23. C 24. A 25. B**
26. C 27. D 28. B 29. B 30. B
31. B 32. B 33. B 34. A 35. D
36. C 37. C 38. C 39. B 40. C

APPRECIATION

If you found these past questions **helpful**, here are some ways you can **contribute** to the exam success of other TOPPERS:

- **Correct an error** in this past question
- **Update** this past question
- **Submit a past question** for another subject

Are you interested in contributing?

Yes, I am!

